Effect of Addition of Dramix 3D Steel Fiber on Compressive Strength and Tensile Strength in Hpc (High-Performance Concrete) Concrete

Agustinus Simangunsong^{1*}, Johannes Tarigan², Nursyamsi³, Ricky Bakara⁴

Universitas Sumatera Utara, Indonesia

Email: agustinussimangunsong@gmail.com^{1*}, johannes.tarigan@usu.ac.id²,
nursyamsi@usu.ac.id³

*Correspondence

ABSTRACT

Keywords: HPC concrete; 3D Dramix steel fiber; compressive strength; tensile strength.

Concrete material is one of the most widely used construction materials in Indonesia due to its high compressive strength and adaptability to various construction needs. Despite its benefits, concrete has limitations, notably its weakness in tension and tendency to crack under tensile stress. This research focuses on High-Performance Concrete (HPC) with compressive strength exceeding 80 MPa, reinforced with 3D Dramix steel fibers to enhance both compressive and tensile strength. The study aimed to evaluate the compressive strength and splitting tensile strength of HPC mixed with varying percentages (0%, 3%, 6%, and 9%) of Dramix 3D steel fibers. Additionally, the methodology involved microstructure analysis using Scanning Electron Microscopy (SEM) and mechanical testing on HPC samples cured at 7, 14, and 28 days. Results indicate that the compressive strength reached a maximum of 94.776 MPa, and tensile strength reached 6.599 MPa with a 9% fiber addition at 28 days, highlighting the material's potential application in high-performance structural elements. The findings suggest that 3D Dramix steel fibers significantly enhance the mechanical properties of HPC, making it a viable option for durable construction.



Introduction

Concrete material is a type of construction material that is very often used and found in construction projects, especially in Indonesia, as well as in the construction of roads, irrigation, buildings, and so on (Fournari & Ioannou, 2019). The things that make concrete materials more often used in construction in Indonesia are that concrete constituents are relatively easy to find in various places with a lower cost budget compared to other types of construction materials, causing concrete materials to be very

often found and used in construction projects in Indonesia. According to (Zaniewski, Bessette, Rashidi, & Bikya, 2012), the characteristics of concrete are that it has a relatively high compressive strength value but a relatively low tensile strength value. The advantages found in concrete materials include relatively high compressive strength values, the material can also be easily shaped, an economical cost budget, good resistance to various conditions that occur in the environment, and concrete materials can be strong and durable (Putra, 2022).

In addition to the advantages of concrete, this material also has disadvantages that cause the service life to be reduced. There are brittle properties in concrete so it makes cracks and can easily be damaged if tensile force is applied. (Alani, Tayeh, Johari, & Majid, 2024). The cause of concrete cracks is when there is excess capacity in the tensile load. Cracks in concrete, when left continuously, can increase corrosion in the steel reinforcement due to the reaction of air and water. The most important focus of this research is to increase the tensile capacity of concrete, namely by researching high-quality concrete or HPC (High-Performance Concrete).

According to (Irianti, Sebayang, & Putra, 2024), high-quality concrete or HPC (High-Performance Concrete) is concrete used with a concrete compressive strength value above 70 MPa and is made like ordinary concrete but added with special materials. According to (Akeed et al., 2022), the requirement for high-quality concrete is the compressive strength value of concrete above 80 MPa.

The fiber material used in the HPC concrete mixture is Dramix 3D steel fiber as the mixture on the concrete. Although there have been many studies that have used Dramix 3D steel fiber as a mixture material in concrete in reinforcement to improve the performance of mechanical properties in concrete, this scientific research is more focused on high-quality concrete or HPC (High-Performance Concrete) with a mixture of Dramix 3D steel fiber. (Baharuddin, Nazri, Bakar, Beddu, & Tayeh, 2020).

This study aims to Evaluate the Effect of 3D Dramix Steel Fiber on Concrete Strength: To assess how the variation in the percentage of 3D Dramix steel fiber (0%, 3%, 6%, and 9%) affects the compressive and tensile strength of High-Performance Concrete (HPC), analyze Microstructure Change: Using Scanning Electron Microscopy (SEM) to observe the microstructure modification in HPC due to the addition of 3D Dramix steel fiber and determine the Optimal Fiber Content: Identify the optimal percentage of Dramix 3D steel fibers to maximize compressive and tensile strength without sacrificing workability. (Wawan, 2024).

Method

Research Stages

There are several stages in the research listed below:

a. Preparation of Research Materials

The materials used in this HPC concrete mixture are PCC type 1 cement, silica powder (silica fume), superplasticizer, river sand, Dramix 3D steel fiber, and also water.

b. Preparation of Research Tools

Effect of Addition of Dramix 3D Steel Fiber on Compressive Strength and Tensile Strength in Hpc (High-Performance Concrete) Concrete

In addition to materials, there are tools used for this research such as concrete cylinder test object molds, mixer boxes, abrams cones, cement spoons, buckets, digital compression machine tests, and measuring tools, namely meters.

c. HPC Concrete Mix Design Mix Planning

The mix design mix planning on HPC concrete refers to the mix design data made by Tayeh, et al. (2013). Especially in this concrete research, the materials used are PCC type 1 cement, silica powder (silica fume), superplasticizer, river sand, water, and the percentage of addition of Dramix 3D steel fiber as stated in Table 2.

Table 1
Mix Design Concrete HPC Mix

| Materials Used | Volume Beton HPC | | | |
|------------------------------|----------------------|-------|-------|-------|
| | 0% | 3% | 6% | 9% |
| | (kg/m ³) | | | |
| Air | 133 | 133 | 133 | 133 |
| Semen PCC Type 1 | 768 | 768 | 768 | 768 |
| Silica Powder | 192 | 192 | 192 | 192 |
| Superplasticizer | 40 | 40 | 40 | 40 |
| River Sand | 1.140 | 1.140 | 1.140 | 1.140 |
| Serat Baja Dramix 3D | - | 4,71 | 9,42 | 14,13 |
| Cement Water Factor (f.a.s.) | 0,173 | 0,173 | 0,173 | 0,173 |
| Rasio w/b | 0,15 | 0,15 | 0,15 | 0,15 |

d. Slump Flow Testing and T50 Testing

The purpose of slump flow testing is to determine the results of flowability in concrete by calculating the diameter of concrete flow after the concrete flow process stops. However, in this test, the first step carried out is the T50 test, which aims to determine the process time of concrete flow until it reaches a flow diameter of 50 cm. The tools used in this test are abrams cones, meter tools, and timing devices. As well as plywood material as a base in slump flow testing by making circle boundaries with a diameter of 20 cm, 50 cm, 65 cm, and also 85 cm. The slump flow testing procedure is that the Abrams cone tool is placed on a plywood board that has been marked in the middle of the circle boundary, then fresh HPC concrete is inserted into the Abrams cone as a note that the fresh concrete is not allowed to have vibration and compaction, it is recommended that the process of fresh HPC concrete is inserted into the cone carefully and does not cause it to spill out from the inside Abrams cones. After that, the cone is lifted on top, and make sure to record the time starting from the beginning of the cone until the flow process reaches a diameter of 50 cm, as the beginning of the T50 test process in seconds. Then after recording the time until it reaches the flow process reaching a diameter of 50 cm, let the concrete continue to flow until it stops and reaches the maximum diameter. Then measure and record the diameter of the slump flow. The

standards on slump flow testing and T50 testing are based on EFNARC regulations and JSFC regulations.

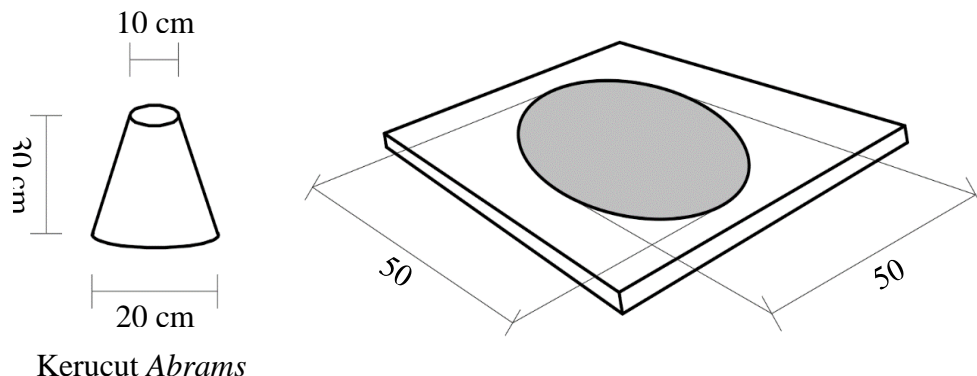

Figure 2
Sketch of Slump Flow Testing Process and T50 Testing on HPC Concrete

e. Sample quantity of HPC Concrete Cylinder Test Specimen

The number of samples and also the dimensions of the HPC concrete cylinder test piece, it is differentiated according to the type of concrete testing. For concrete test pieces used in compressive strength testing use concrete cylinders with a height of 20 cm and a diameter of 10 cm, and for concrete test specimens used in concrete tensile strength testing use concrete cylinders with a height of 19.6 cm and a diameter of 12.5 cm. Samples of HPC concrete cylinder test pieces are loaded in Table 3. below.

Table 3
Sample quantity of HPC Concrete Cylinder Test Specimen

| Concrete Test No. | Concrete Specimen Sample Code | Cylinder Specimen According to Testing | | | |
|-------------------|-------------------------------|--|-------------|-------------|---------------------------------|
| | | Compressive Strength of Concrete | | | Tensile Strength Concrete Slats |
| | | 7 Days Old | Age 14 Days | Age 28 Days | Age 28 days |
| | | | | | |
| 1 | BOO-0% | 3 | 3 | 3 | 3 |
| 2 | BOO-3% | 3 | 3 | 3 | 3 |
| 3 | BOO-6% | 3 | 3 | 3 | 3 |
| 4 | BOO-9% | 3 | 3 | 3 | 3 |

f. HPC Concrete Volume Weight Inspection

After the HPC concrete test piece has been made, then an HPC concrete volume weight check is carried out which is defined as the weight check of concrete after being weighed and distributed with the calculation of the volume of the concrete cylinder test

Effect of Addition of Dramix 3D Steel Fiber on Compressive Strength and Tensile Strength in Hpc (High-Performance Concrete) Concrete

piece. In Table 4. The types of concrete based on the weight of the volume of concrete according to Tjokrodumuljo (2007) are listed as follows.

Table 4
Types of Concrete Based on Concrete Volume Weight Inspection

| Types of Concrete | Volume Weight (kg/m ³) | Concrete Function |
|-------------------------------------|------------------------------------|-----------------------|
| Ultra-light concrete | < 1,000 | Non-structure |
| Lightweight Concrete | 1.000 – 2.000 | Lightweight structure |
| Concrete Normal (Ordinary Concrete) | 2.300 – 2.500 | Structure |
| Heavy Concrete | > 3,000 | X-ray shielding |

g. HPC Concrete Compressive Strength Testing

According to Wang and Salmon (1990), the compressive strength of concrete is a test of a load pressed by a machine per unit area of a concrete base so that the concrete test piece is destroyed due to a compressive force affected by the press. The formula for testing the compressive strength of concrete is listed in equation (1) below as follows.

$$f_c = \frac{P}{\frac{1}{4} \cdot \pi \cdot D^2} \dots\dots\dots (1)$$

Where: f_c = Compressive strength of concrete (kN/m²)
 P = Compressive force on concrete (kN)
 D = Diameter on concrete cylinder (m)

h. Concrete Screed Tensile Strength Testing

According to SNI 2491:2014, concrete tensile strength is a test to determine the value of concrete tensile strength indirectly through a test piece cylinder placed in a horizontal position and parallel to the table surface before the testing machine is pressed. The formula for testing the tensile strength of concrete is listed in equation (2) below as follows.

$$f_{ct} = \frac{2P}{\pi \cdot L_s \cdot D} \dots\dots\dots (2)$$

Information:
 Fact = Tensile strength of concrete slats (kN/m²)
 P = Maximum tensile load applied (kN)
 L_s = Height on concrete cylinder (m)
 D = Diameter in concrete cylinder (m)

Results and Discussion

Results of Slump Flow Testing and T50 Testing on HPC Concrete

The test begins with the creation of a mix design on HPC fresh concrete which is added with the percentage of 3D dramix steel fiber. In Table 5. and Figure 3.

Table 5
Slump Flow Test Results on HPC Concrete

| No. | Percentage Addition of Dramix 3D Steel Fiber | Diameter Slump Flow (cm) | Standard EFNARC (55 – 85 cm) | Standard JSCE (50 – 65 cm) |
|-----|--|--------------------------|------------------------------|----------------------------|
| 1 | 0% | 100,6 | Not OK! | Not OK! |
| 2 | 3% | 95,4 | Not OK! | Not OK! |
| 3 | 6% | 89,8 | Not OK! | Not OK! |
| 4 | 9% | 86,3 | Not OK! | Not OK! |

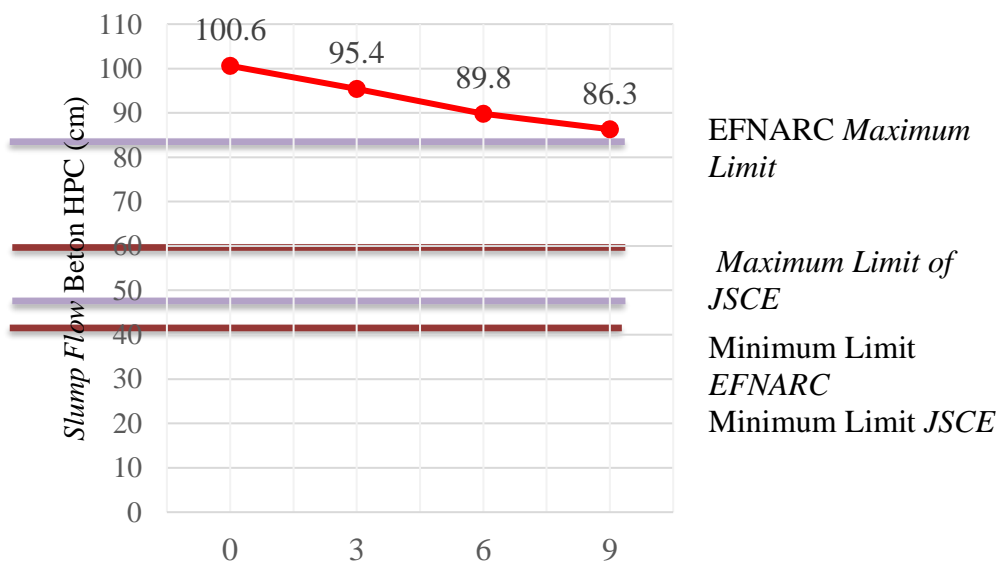

Figure 3
Relationship of Slump Flow to the Addition of 3D Dramix Steel Fiber

After calculating the slump flow of HPC concrete, the T50 test was carried out. Below is also attached the T50 test data in Table 6. and Figure 4. below.

Effect of Addition of Dramix 3D Steel Fiber on Compressive Strength and Tensile Strength in Hpc (High-Performance Concrete) Concrete

Table 6
T50 Test Results on HPC Concrete

| No. | Percentage Addition of Dramix 3D Steel Fiber | T50 (sec) | Standard EFNARC (55 – 85 cm) | Standard JSCE (50 – 65 cm) |
|-----|--|-----------|------------------------------|----------------------------|
| 1 | 0% | 05,56 | OK! | OK! |
| 2 | 3% | 06,21 | OK! | OK! |
| 3 | 6% | 06,90 | Not OK! | OK! |
| 4 | 9% | 07,68 | Not OK! | OK! |

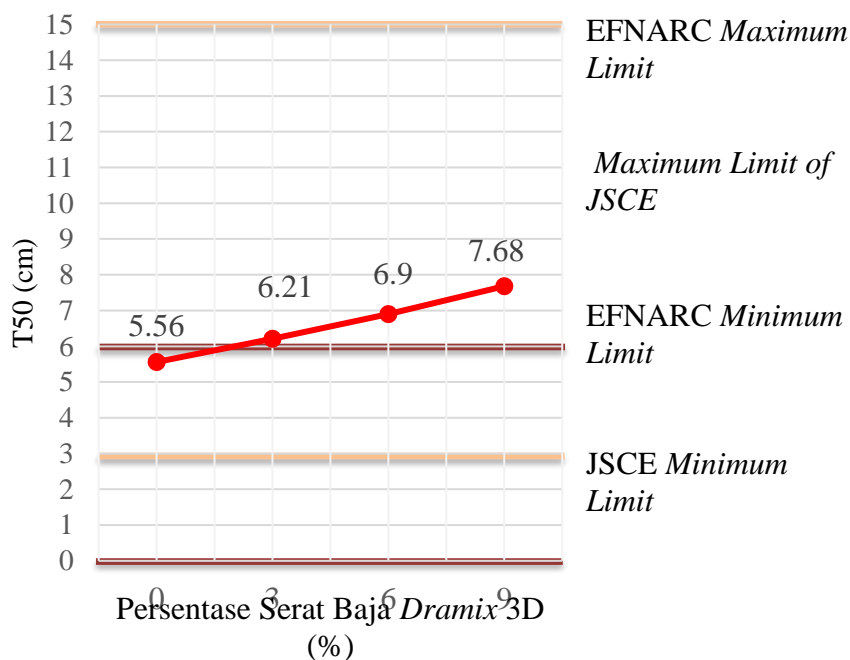

Figure 4
Relationship of T50 Testing to the Addition of 3D Dramix Steel Fiber

From the results of the HPC (High-Performance Concrete) concrete slump flow test above, it can be concluded that the more the percentage of 3D dramatic steel fibers increases, the diameter flow in fresh concrete will decrease, this event is due to a decrease in workability in concrete with the addition of a percentage of 3D dramatic steel fibers. Then from the results of the T50 test on HPC concrete (High-Performance Concrete) above can be concluded that the higher the percentage of 3D dramatic steel fiber, the slower the flow process time of the diameter of fresh concrete, this incident is

caused by the components of the mix in fresh concrete are held by the 3D dramatic steel fiber so that it can slow down the flow in fresh concrete.

Results of Volume Weight Inspection on HPC Concrete

After the slump flow test and the T50 test on HPC concrete, the next testing process is the weight check of the volume of HPC concrete for the test specimen cylinder in the concrete compressive strength test and also the concrete tensile strength test specimen cylinder. It is known that the dimensions of cylindrical test pieces are differentiated according to their respective mechanical magnitude tests. HPC concrete volume weight inspection data for concrete compressive strength testing are in Table 7, Table, and Table 9 below.

Tabel 7
Hasil Pemeriksaan Berat Volume Beton HPC untuk
Pengujian Kuat Tekan Beton 7 Hari

| Specimen Code | Weight of Concrete Test Specimen (kg) | Volume of Concrete (m3) | Concrete Volume Weight (kg/m3) | Concrete Volume Weight Average (kg/m3) |
|---------------|---------------------------------------|-------------------------|--------------------------------|--|
| BOO – 0% | 4,440 | 0,0015714 | 2.825,455 | 2.812,727 |
| | 4,320 | | 2.749,091 | |
| | 4,500 | | 2.863,636 | |
| BOO – 3% | 4,480 | 0,0015714 | 2.850,909 | 2.829,697 |
| | 4,440 | | 2.825,455 | |
| | 4,420 | | 2.812,727 | |
| BOO – 6% | 4,600 | 0,0015714 | 2.927,273 | 2.855,152 |
| | 4,480 | | 2.850,909 | |
| | 4,380 | | 2.787,273 | |
| BOO – 9% | 4,500 | 0,0015714 | 2.863,636 | 2.879,364 |
| | 4,400 | | 2.800 | |
| | 4,660 | | 2.965,455 | |

Table 8
HPC Concrete Volume Weight Inspection Results for
14 Days Concrete Compressive Strength Test

| Specimen Code | Weight of Concrete Test Specimen (kg) | Volume of Concrete (m3) | Concrete Volume Weight (kg/m3) | Concrete Volume Weight Average (kg/m3) |
|---------------|---------------------------------------|-------------------------|--------------------------------|--|
| BOO – 0% | 4,440 | 0,0015714 | 2.825,455 | 2.749,091 |
| | 4,180 | | 2.660 | |
| | 4,340 | | 2.761,818 | |
| BOO – 3% | 4,340 | 0,0015714 | 2.761,818 | 2.766,061 |
| | 4,320 | | 2.749,091 | |
| | 4,380 | | 2.787,273 | |
| BOO – 6% | 4,540 | 0,0015714 | 2.889,091 | 2.829,697 |
| | 4,420 | | 2.812,727 | |

Effect of Addition of Dramix 3D Steel Fiber on Compressive Strength and Tensile Strength in Hpc (High-Performance Concrete) Concrete

| | | | | |
|----------|-------|-----------|-----------|-----------|
| | 4,380 | | 2.787,273 | |
| BOO – 9% | 4,700 | 0,0015714 | 2.990,909 | 2.897,576 |
| | 4,440 | | 2.825,455 | |
| | 4,520 | | 2.876,364 | |
| | | | | |

Table 9
HPC Concrete Volume Weight Inspection Results for
14 Days Concrete Compressive Strength Test

| Specimen Code | Weight of Concrete Test Specimen (kg) | Volume of Concrete (m3) | Concrete Volume Weight (kg/m3) | Concrete Volume Weight Average (kg/m3) |
|---------------|---------------------------------------|-------------------------|--------------------------------|--|
| BOO – 0% | 3,820 | 0,0015714 | 2.430,909 | 2.439,394 |
| | 3,860 | | 2.456,364 | |
| | 3,820 | | 2.430,909 | |
| BOO – 3% | 3,950 | 0,0015714 | 2.513,636 | 2.515,758 |
| | 3,980 | | 2.532,727 | |
| | 3,930 | | 2.500,909 | |
| BOO – 6% | 4,060 | 0,0015714 | 2.583,636 | 2.564,545 |
| | 3,970 | | 2.526,364 | |
| | 4,060 | | 2.583,636 | |
| BOO – 9% | 4,170 | 0,0015714 | 2.653,636 | 2.689,697 |
| | 4,230 | | 2.691,818 | |
| | 4,280 | | 2.723,636 | |

The data from the weight inspection of HPC concrete volume for concrete compressive strength testing are in Table 7, Table 8, and Table 9. Above it is concluded that the average weight value of concrete volume with the percentage addition of 0%, 3%, 6%, and 9% in 3D dramatic steel fiber for the immersion life of 7 days, 14 days, and 28 days are categorized as heavy concrete, This is because the average weight of concrete volume has reached more than 2,500 kg/m³. After that, the weight of the HPC concrete volume is checked for the tensile strength of the concrete contained in Table 10. below as follows.

Table 10
Results of Volume Weight Inspection on 28-Day-Old HPC Concrete
for Concrete Tensile Strength Testing

| Specimen Code | Weight of Concrete Test Specimen (kg) | Volume of Concrete (m3) | Concrete Volume Weight (kg/m3) | Concrete Volume Weight Average (kg/m3) |
|---------------|---------------------------------------|-------------------------|--------------------------------|--|
| BOO – 0% | 12,420 | 0,0053036 | 2.341,818 | 2.326,734 |

| | | | | |
|----------|--------|-----------|-----------|-----------|
| | 12,340 | | 2.326,734 | |
| | 12,260 | | 2.311,650 | |
| BOO – 3% | 12,740 | 0,0053036 | 2.402,155 | 2.429,809 |
| | 13,020 | | 2.454,949 | |
| | 12,900 | | 2.432,323 | |
| BOO – 6% | 12,940 | 0,0053036 | 2.439,865 | 2.451,178 |
| | 13,120 | | 2.473,805 | |
| | 12,940 | | 2.439,865 | |
| BOO – 9% | 13,200 | 0,0053036 | 2.488,889 | 2.498,945 |
| | 13,220 | | 2.492,660 | |
| | 13,340 | | 2.515,286 | |

In the results of the weight check of HPC concrete volume 28 days immersion age for the tensile strength test of concrete above, it can be concluded that the average weight of concrete volume with an increase of 0%, 3%, 6%, and 9% of 3D dramatic steel fiber is categorized as normal concrete, this has been in accordance with the requirements of the type of concrete at the limit of 2,300 – 2,500 kg/m³.

HPC Concrete Compressive Strength Test Results

For the cylinder of the HPC concrete test piece used in the testing of concrete compressive strength with a diameter of 10 cm and a height of 20 cm, then the concrete soaking process is carried out within 7 days, 14 days, and 28 days. The results of HPC concrete compressive strength tests can be seen in Table 11., Table 12., and Table 13. below below.

Table 11
HPC Concrete Compressive Strength Test Results for 7 Days Immersion Life

| Specimen Code | Maximum Load (kN) | Average Maximum Load (kN) | Compressive Strength of Concrete (MPa) | Compressive Strength of Concrete Average (MPa) |
|---------------|-------------------|---------------------------|--|--|
| BOO – 0% | 313 | 225,667 | 39,836 | 28,721 |
| | 285 | | 36,273 | |
| | 79 | | 10,055 | |
| BOO – 3% | 454 | 383,333 | 57,782 | 48,788 |
| | 494 | | 62,873 | |
| | 202 | | 25,709 | |
| BOO – 6% | 541 | 429,333 | 68,855 | 54,642 |
| | 394 | | 50,145 | |
| | 353 | | 44,927 | |
| BOO – 9% | 384 | 508 | 48,873 | 64,655 |
| | 601 | | 76,491 | |
| | 539 | | 68,600 | |

Table 12
HPC Concrete Compressive Strength Test Results for 14 Days Immersion Life

| Specimen Code | Maximum Load (kN) | Average Maximum Load (kN) | Compressive Strength of Concrete (MPa) | Compressive Strength of Concrete Average (MPa) |
|----------------------|--------------------------|----------------------------------|---|---|
| BOO – 0% | 231 | 352,333 | 29,400 | 44,842 |
| | 406 | | 51,673 | |
| | 420 | | 53,455 | |
| BOO – 3% | 421 | 448,667 | 53,582 | 57,103 |
| | 493 | | 62,745 | |
| | 432 | | 54,982 | |
| BOO – 6% | 498 | 619,667 | 63,382 | 78,867 |
| | 606 | | 77,127 | |
| | 755 | | 96,091 | |
| Specimen Code | Maximum Load (kN) | Average Maximum Load (kN) | Compressive Strength of Concrete (MPa) | Compressive Strength of Concrete Average (MPa) |
| BOO – 9% | 377 | 664,667 | 47.982 | 84,594 |
| | 731 | | 93.036 | |
| | 886 | | 112.764 | |

Table 13
Hasil Pengujian Kuat Tekan Beton HPC untuk Umur Perendaman 28 Hari

| Specimen Code | Maximum Load (kN) | Average Maximum Load (kN) | Compressive Strength of Concrete (MPa) | Compressive Strength of Concrete Average (MPa) |
|----------------------|--------------------------|----------------------------------|---|---|
| BOO – 0% | 241 | 478,667 | 30,673 | 60,921 |
| | 660 | | 84,000 | |
| | 535 | | 68,091 | |
| BOO – 3% | 602 | 534 | 76,618 | 67,964 |
| | 462 | | 58,800 | |
| | 438 | | 68,473 | |

| | | | | |
|----------|-----|---------|---------|--------|
| BOO – 6% | 530 | 648,333 | 67,455 | 82,515 |
| | 524 | | 66,691 | |
| | 891 | | 113,400 | |
| BOO – 9% | 768 | 744,667 | 97,745 | 94,776 |
| | 783 | | 99,655 | |
| | 683 | | 86,927 | |

Below is attached a compressive strength test graph of HPC concrete in Figure 5. below.

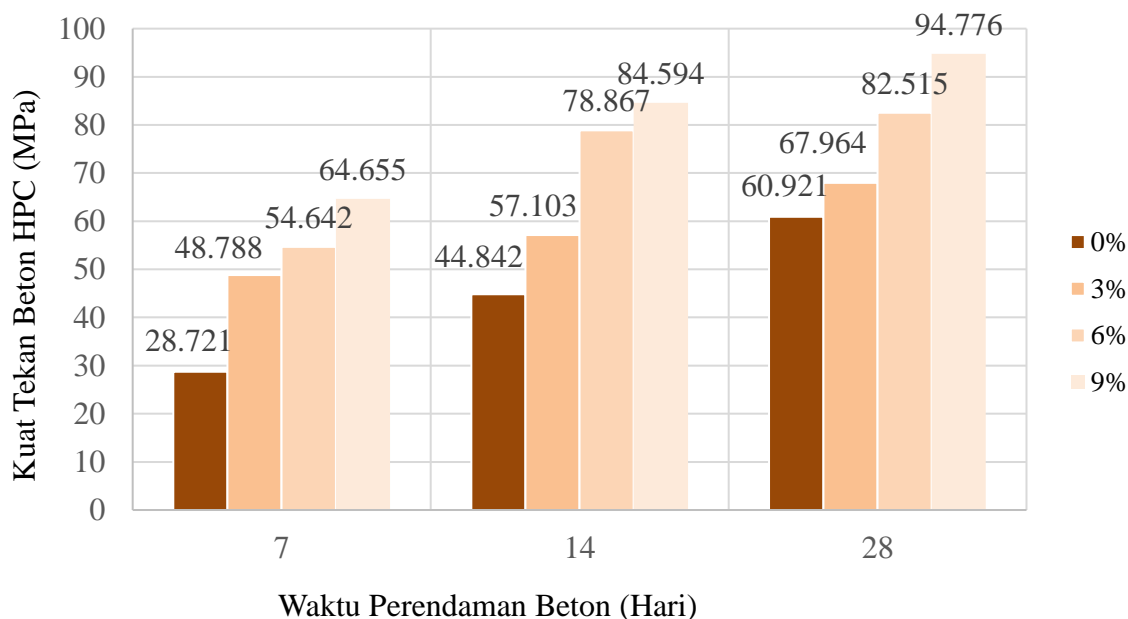

Figure 5
HPC Concrete Compressive Strength Testing Chart

Based on the data of the table and graph above, it is concluded that there is an increase in the compressive strength value of concrete both in the percentage of addition of 3D dramatic steel fiber and the time of soaking concrete. It can be seen that concrete for 14 days with 9% fiber (84,594 MPa), concrete for 28 days with 6% fiber (82,515 MPa), and concrete for 28 days with 9% fiber (94,776 MPa) is declared as HPC (High-Performance Concrete), this is because the limit of the compressive strength value of concrete exceeds 80 Mpa. (Wahjudi, Satyarno, & Tjokrodimuljo, 2010).

HPC Concrete Tensile Strength Test Results

Below are the results of the tensile strength test of HPC concrete in Table 14. below as follows.

Table 14
Results of 28 Days HPC Concrete Tensile Strength Test

Effect of Addition of Dramix 3D Steel Fiber on Compressive Strength and Tensile Strength in Hpc (High-Performance Concrete) Concrete

| Specimen Code | Maximum Load (kN) | Average Maximum Load (kN) | Strong Tensile Strength of Concrete (MPa) | Strong Tensile Strength of Concrete Average (MPa) |
|---------------|-------------------|---------------------------|---|---|
| BOO – 0% | 150 | 153,333 | 2,121 | 2,168 |
| | 170 | | 2,404 | |
| | 140 | | 1,980 | |
| BOO – 3% | 150 | 186,667 | 2,121 | 2,640 |
| | 160 | | 2,263 | |
| | 250 | | 3,535 | |
| BOO – 6% | 300 | 320 | 4,242 | 4,525 |
| | 310 | | 4,384 | |
| | 350 | | 4,949 | |
| BOO – 9% | 440 | 466,667 | 6,222 | 6,599 |
| | 410 | | 5,798 | |
| | 550 | | 7,778 | |

After Table 14. is made, then the concrete tensile strength test graph is attached in Figure 6. below as follows.

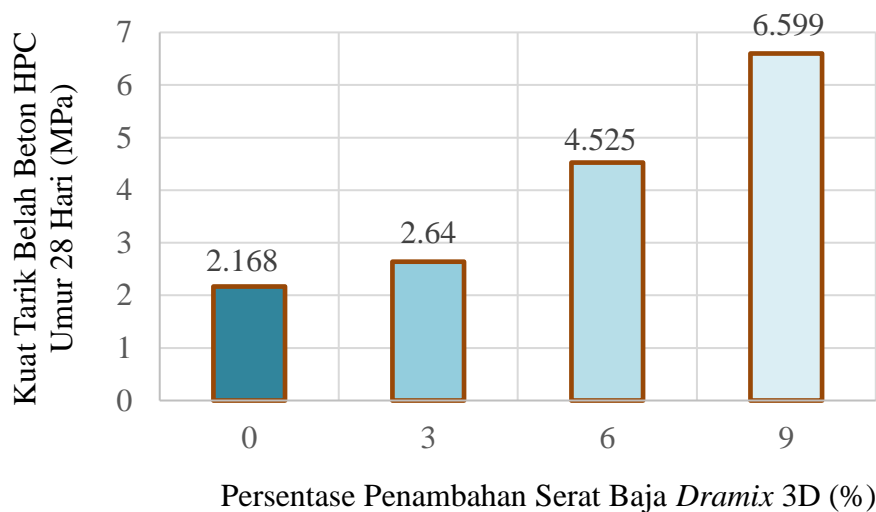

Figure 6
HPC Concrete Tensile Strength Testing Chart for 28 Days Lifespan

In Table 14 data. And Figure 6. Above it can be concluded that the tensile strength value of concrete has increased well based on the percentage of addition of 3D dramatic steel fiber (Tjokrodimuljo, 2007). It can be seen that the concrete with the lowest tensile strength value of concrete is concrete without 3D dramix steel fiber, which is 2.168 MPa and the highest concrete tensile strength value is concrete with a percentage of 9% 3D dramix steel fiber, which is 6.599 Mpa.

Conclusion

In the above study, the author concludes that the compressive strength testing of concrete and the tensile strength testing of concrete has increased according to the percentage of addition of 0%, 3%, 6%, and 9% of 3D dramatic steel fiber and the soaking time of 7 days, 14 days, and 28 days. The addition of 3D dramatic steel can be used as a substitute for steel fiber for HPC (High-Performance Concrete) concrete mixtures because there is concrete that can reach concrete compressive strength values above 80 MPa. However, the addition of the percentage of 3D dramix steel fiber to concrete has decreased workability due to the addition of superplasticizer material until in the slump flow test, there is no noticeable difference in the concrete flow process compared to concrete by not using the addition of 3D dramix steel fiber.

Bibliography

- Akeed, Mahmoud H., Qaidi, Shaker, Faraj, Rabar H., Mohammed, Ahmed S., Emad, Wael, Tayeh, Bassam A., & Azevedo, Afonso R. G. (2022). Ultra-high-performance fiber-reinforced concrete. Part II: Hydration and microstructure. *Case Studies in Construction Materials*, 17, e01289.
- Alani, Aktham H., Tayeh, Bassam A., Johari, Megat Azmi Megat, & Majid, T. A. (2024). Optimizing strength behavior of sustainable ultra high-performance green concrete with minimum cement content using response surface method. *Journal of Building Pathology and Rehabilitation*, 9(2), 110.
- Baharuddin, Nur Khaida, Nazri, Fadzli Mohamed, Bakar, Badorul Hisham Abu, Beddu, Salmia, & Tayeh, Bassam A. (2020). Potential use of ultra-high-performance fiber-reinforced concrete as a repair material for fire-damaged concrete in terms of bond strength. *International Journal of Integrated Engineering*, 12(9), 87–95.
- Fournari, Revecca, & Ioannou, Ioannis. (2019). Correlations between the properties of crushed fine aggregates. *Minerals*, 9(2), 86.
- Irianti, Laksmi, Sebayang, Surya, & Putra, Rivaldo Hartono. (2024). The effect of fly ash and silica fume content on the compressive strength of high-strength concrete. *AIP Conference Proceedings*, 2970(1). AIP Publishing.
- Putra, Rivaldo Hartono. (2022). Kuat Tekan Beton Mutu Tinggi Dengan Memanfaatkan Fly Ash dan Silica Fume Sebagai Bahan Pengisi.
- Tjokrodinuljo, Kardiyono. (2007). TEKNOLOGI BETON, Jurusan Teknik Sipil. Fakultas Teknik Universitas Gadjah Mada, Yogyakarta.
- Wahjudi, Antonius, Satyarno, Imam, & Tjokrodinuljo, Kardiyono. (2010). Penggunaan pasir tailing timah dan batu pecah granit dari Pulau Bangka untuk beton normal. Thesis. Universitas Gadjah Mada.
- Wawan, Riswandy. (2024). Analisis Kuat Tekan Beton Menggunakan Serbuk Batu Bata Merah Sebagai Substitusi Parsial Semen. Universitas Islam Kalimantan MAB.
- Zaniewski, John P., Bessette, Logan, Rashidi, Hadi, & Bikya, Rajasekhar. (2012). Evaluation of Methods for Measuring Aggregate Specific Gravity. Department of Civil and Environmental Engineering Morgantown, West Virginia.