

## Intake Planning in Loma River, Tolikara Regency

Helen Gianditha Wayangkau<sup>1\*</sup>, Amaliah Azis<sup>2</sup>, Alfian Adie Chandra<sup>3</sup>, David<sup>4</sup>,  
Davy I. Robert Jansen<sup>5</sup>

Universitas Cenderawasih, Indonesia<sup>1,2,3,4,5</sup>

Email : [helenwayangkau97@gmail.com](mailto:helenwayangkau97@gmail.com)<sup>1\*</sup>, [amaliahazis68@gmail.com](mailto:amaliahazis68@gmail.com)<sup>2</sup>,  
[alfiansipiluncen@gmail.com](mailto:alfiansipiluncen@gmail.com)<sup>3</sup>, [davidmanggalatung@yahoo.com](mailto:davidmanggalatung@yahoo.com)<sup>4</sup>,  
[dave.jansen04@gmail.com](mailto:dave.jansen04@gmail.com)<sup>5</sup>

\*Correspondence

### ABSTRACT

**Keywords:** Raw Water;  
River; Intake Building

The provision of clean water in Karubaga City has been hampered by inadequate piping distribution networks, forcing reliance on drilled wells in villages. This study aims to address the problem of inadequate clean water facilities by planning an effective water intake system for the Loma River in Tolikara Regency. Using a combination of quantitative and qualitative methods, the research analyzed hydrological data, intake hydraulics, and the structural stability of intake buildings. Results indicate that the Loma Intake requires significant rehabilitation due to sediment deposition, while the Palagi Intake needs an evaluation of the pipeline network to improve flow pressure and distribution. The study concludes that redesigning and constructing efficient water intake systems is crucial to meeting the community's clean water needs while mitigating health risks from water pollution.



### Introduction

Human life is inseparable from the need for water (Kılıç, 2020). Water is needed to meet various needs, especially clean water or drinking water that is needed to ensure human survival. Therefore, the provision of clean water needs to be sought both by the government and the community itself. The clean water used must meet the requirements both in terms of quantity and quality (WHO, 2022). Various technologies have been used to provide and treat raw water in such a way that it meets the requirements of clean water and drinking water (Darmasetiawan, 2004; Gabrielle et al., 2021). Law No. 7 of 2004 article 40 paragraph 1 states that the need for raw water for household drinking water is carried out by developing a drinking water supply system (Pemerintah Pusat, 2004).

The need for clean water in the Mountainous Papua Province, especially Tolikara Regency, continues to increase annually, driven by the rapid development of the region (BPS Papua, 2021). To meet the clean water needs of residents in Tolikara Regency, various water sources are currently utilized, including river water, shallow groundwater (dug wells), deep groundwater (drilled wells), and rainwater (Direktorat Jenderal Sumber

Daya Air, 2013). The Loma River is one of the water sources relied upon by the community for daily needs. However, a critical requirement for the community is a clean water network. The raw water facilities and infrastructure in Tolikara Regency remain incomplete; some installed systems face issues preventing them from adequately meeting community needs (Aboagye et al., 2022; Gupta et al., 2021; Setyaninditha et al., 2021). In addition, many water sources remain unutilized due to their remote locations, the absence of pipeline networks, and the lack of water intake buildings. A raw water intake building, constructed at a water source such as rivers, springs, or groundwater, is designed to capture and provide water for drinking purposes. Given these challenges, conducting an intake planning study is crucial to identify the optimal intake location.

This research addresses the critical problem of providing sustainable and efficient clean water infrastructure in Tolikara Regency, with a focus on intake planning for the Loma River. The existing intake facilities in the region are either damaged or insufficient, such as the Loma Intake, which is buried in sediment and requires major rehabilitation. Moreover, the current water distribution systems fail to adequately serve urban populations, highlighting the need for comprehensive evaluation and redesign.

The importance of this research lies in its potential to significantly improve the quality of life for the Tolikara community by ensuring access to clean and safe water. By employing both quantitative and qualitative methods, this study analyzes hydrology, intake hydraulics, and intake structure stability to propose innovative and effective solutions. The novelty of this research lies in its focus on designing a tailored water intake system that addresses the specific challenges of the region, considering its geographical, environmental, and socio-economic factors.

The purpose of this study is to make a raw water intake plan to overcome the problem of clean water in the Tolikara Regency community.

## **Methods**

This research is located in Tolikara Regency, Karubaga District. The district is geographically located at 138° 00'00" - 139° 00'00" East Longitude and 0° 00'00" - 4° 00'00" South Latitude. Administratively, Tolikara Regency is administratively bordered by Mamberamo Raya and Sarimi Regency to the North, Bordered by Jayawijaya Regency to the South, Bordered by Jayawijaya Regency to the East, and Bordered by Puncak Jaya Regency to the West.

The methods that will be used in this study are quantitative and qualitative methods. Quantitative is intended to provide explanation, assessment and analysis using measurable quantities, expressed in numbers. A quantitative approach is used to analyze hydrology to obtain the design flood discharge and mainstay discharge, intake hydraulics to obtain the intake dimension size and intake stability to control the safety of the designed intake building. The data taken are primary data and secondary data.

### **1. Data Primer**

Primary data is all data obtained directly from the field survey process. The data is searched and collected by researchers from their observation objects using

measurement tools, survey forms, and celebration lists (questionnaires). The primary data in question are:

- a. Topography
  - b. Hydrology
  - c. Hydrica
  - d. Geology
  - e. Socio-Economic and environmental circumstances
2. Data Seconds

Secondary data is data or information obtained in a structured data format and sourced from government and private agencies that are relevant to the objectives of this research such as:

- a. Rainfall data
- b. Data Climatology
- c. Topographic map data.

## Results and Discussion

### 1. Population Projections

The rate of population growth is calculated from the population growth data of all Tolikara Regency as seen in Table 1.

**Table 1. Population Growth Rate**

| It | Regency/City | District | Total Population in 2022 (Persons) | Population Growth Ratio (%) |
|----|--------------|----------|------------------------------------|-----------------------------|
| 1  | Tolikara     | Karubaga | 18003                              | 1.85                        |

Source: BPS Papua Province, 2021

#### a. Geometric Method

From the results of the calculation of population growth using the Geometric Method, the number of population can be projected up to 25 years and can be seen in the following table:

**Table 2. Recapitulation of the 25-Year Population Projection of Mountainous Papua Province**

| Year | n  | Jumlah Penduduk (Jiwa) |       |          |         |        |       |         |        |
|------|----|------------------------|-------|----------|---------|--------|-------|---------|--------|
|      |    | Wamena                 | Tiom  | Karubaga | Kobakma | Elelim | Dekai | Oksibil | Kenyam |
| 2020 | 0  | 65766                  | 11013 | 17676    | 13504   | 16675  | 17316 | 6408    | 6157   |
| 2025 | 5  | 72079                  | 11899 | 19373    | 14369   | 18276  | 18978 | 6576    | 6712   |
| 2030 | 10 | 78997                  | 12857 | 21232    | 15290   | 20030  | 20800 | 6749    | 7316   |
| 2035 | 15 | 86580                  | 13891 | 23270    | 16270   | 21952  | 22796 | 6926    | 7975   |
| 2040 | 20 | 94890                  | 15009 | 25502    | 17313   | 24059  | 24984 | 7108    | 8694   |
| 2045 | 25 | 103999                 | 16217 | 27952    | 18422   | 26369  | 27383 | 7295    | 9477   |

Source: Calculation Results, 2024

## 2. Projected Water Needs

In accordance with the Framework of Reference, water demand projections are carried out for the next 25 years (Müller Schmied et al., 2021). By taking 2020-2022 as the beginning of the plan, water demand in Tolikara Regency is projected with an interval of 5 years until 2045. The results of water needs in Tolikara Regency (Karubaga) are attached in Table 3.

**Table 3. Projected Water Needs of Tolikara Regency (Karubaga) until 2045**

| It | Description / Criteria      | Unit      | Projected Year |           |           |           |           |           |
|----|-----------------------------|-----------|----------------|-----------|-----------|-----------|-----------|-----------|
|    |                             |           | 2020           | 2025      | 2030      | 2035      | 2040      | 2045      |
| 1  | Household Needs (Domestic)  |           |                |           |           |           |           |           |
| -  | Population                  | (soul)    | 17676          | 19373     | 21232     | 23270     | 25504     | 27952     |
| -  | Number of Population Served | (soul)    | 10606          | 12592     | 14863     | 17453     | 20403     | 23759     |
| -  | Served with SR              | (soul)    | 6363           | 7870      | 9661      | 11781     | 14282     | 17225     |
| -  | Served through HU           | (soul)    | 4242           | 4722      | 5202      | 5672      | 6121      | 6534      |
| -  | SR Needs                    | (m3/d ay) | 636            | 826       | 1063      | 1355      | 1714      | 2153      |
| -  | HU Needs                    | (m3/d ay) | 127            | 142       | 156       | 170       | 184       | 196       |
| -  | Number of household needs   | (m3/d ay) | 764            | 968       | 1219      | 1525      | 1897      | 2349      |
| 2  | Non-Domestic Needs          | (m3/d ay) | 191            | 281       | 406       | 578       | 813       | 1007      |
| 3  | Total (1+2)                 | (m3/d ay) | 955            | 1249      | 1625      | 2103      | 2711      | 3356      |
| 4  | Water Loss                  | (m3/d ay) | 191            | 250       | 325       | 421       | 542       | 671       |
| 5  | Average Daily Needs         |           | 1145           | 1499      | 1950      | 2524      | 3253      | 4027      |
| 6  | Maximum Daily Needs         | (m3/d ay) | 1260           | 1649      | 2145      | 2776      | 3578      | 4430      |
|    |                             | (lt/sec ) | 14.58          | 19.08     | 24.83     | 32.13     | 41.41     | 51.27     |
|    |                             | (m3/s)    | 0.01           | 0.02      | 0.02      | 0.03      | 0.04      | 0.05      |
|    |                             | (lt/day ) | 1,259,945      | 1,648,769 | 2,144,958 | 2,776,412 | 3,578,108 | 4,429,872 |
| 7  | Peak Hour Needs             | (m3/d ay) | 1890           | 2473      | 3217      | 4165      | 5367      | 6645      |
|    |                             | (lt/sec ) | 21.87          | 28.62     | 37.24     | 48.20     | 62.12     | 76.91     |

(Source: Calculation Results, 2024)

### 3. Reliable Discharge and Water Balance

The results of the calculation of discharge with 80% reliability (Q80) in all rivers in Tolikara Regency are shown in order in the following Table 4.

**Table 4. Results of Calculation of Reliable Discharge on the Loma River**

| No | Moon | Water Availability, Q80 (m3/s) |
|----|------|--------------------------------|
|    |      | S. Loma                        |
| 1  | Jan  | 0.4332                         |
| 2  | Feb  | 0.4347                         |
| 3  | Mar  | 0.4344                         |
| 4  | Apr  | 0.4346                         |
| 5  | May  | 0.4336                         |
| 6  | Jun  | 0.4338                         |
| 7  | Jul  | 0.4336                         |
| 8  | Aug  | 0.4334                         |
| 9  | Sep  | 0.4336                         |
| 10 | Oct  | 0.4336                         |
| 11 | Nov  | 0.4337                         |
| 12 | Some | 0.4326                         |

(Source: Calculation Results, 2024)

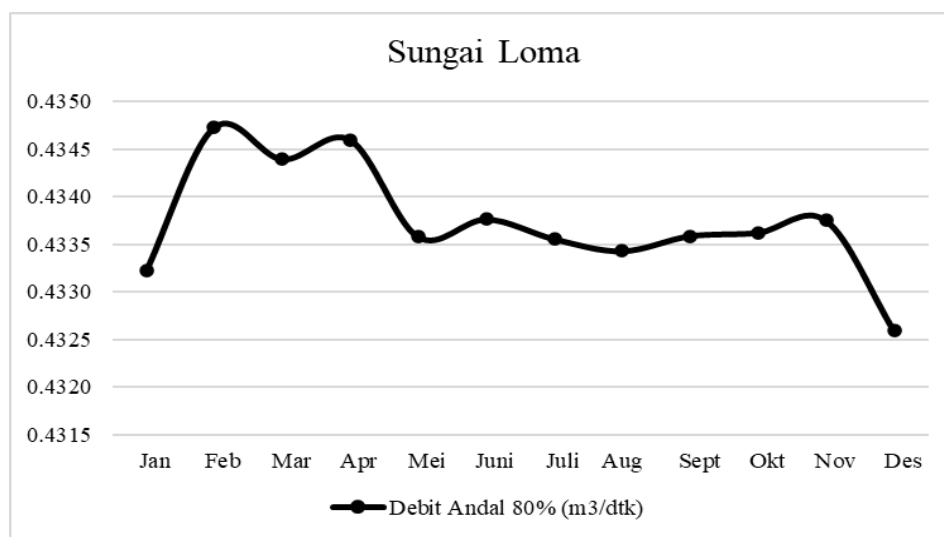

**Figure 1. Reliable Discharge (Q80) of Loma River**

The results of the water demand projection show a comparison between water demand and water availability in Tolikara Regency.

**Table 5. Results of Calculation of Reliable Discharge of Loma River**

| No | Moon | Water Availability, Q80 (m3/s) | Water              |                |
|----|------|--------------------------------|--------------------|----------------|
|    |      |                                | Requirement (m3/s) | Surplus (m3/s) |
| 1  | Jan  | 0.4332                         | 0.02               | 0.4127         |

| No | Moon | Water Availability, Q80 (m3/s) | Water              |                |
|----|------|--------------------------------|--------------------|----------------|
|    |      |                                | Requirement (m3/s) | Surplus (m3/s) |
| 2  | Feb  | 0.4347                         | 0.02               | 0.4142         |
| 3  | Mar  | 0.4344                         | 0.02               | 0.4139         |
| 4  | Apr  | 0.4346                         | 0.02               | 0.4141         |
| 5  | May  | 0.4336                         | 0.02               | 0.4131         |
| 6  | Jun  | 0.4338                         | 0.02               | 0.4133         |
| 7  | Jul  | 0.4336                         | 0.02               | 0.4130         |
| 8  | Aug  | 0.4334                         | 0.02               | 0.4129         |
| 9  | Sep  | 0.4336                         | 0.02               | 0.4131         |
| 10 | Oct  | 0.4336                         | 0.02               | 0.4131         |
| 11 | Nov  | 0.4337                         | 0.02               | 0.4132         |
| 12 | Some | 0.4326                         | 0.02               | 0.4121         |

(Source: Calculation Results, 2024)

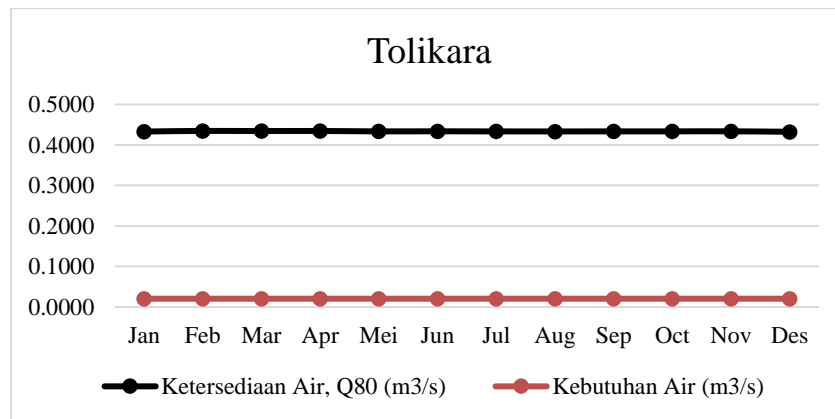

Figure 2. Comparison of Water Availability and Water Needs of Tolikara

#### 4. Flood Discharge Plan

Table 6. Recapitulation of the results of the Tolikara Distribution Conformity test

| No | Distribution Type | Condition                | Calculation Results       | Conclusion    |
|----|-------------------|--------------------------|---------------------------|---------------|
| 1  | Normal            | Cs= 0<br>Ck = 3          | Cs= 0.46<br>Ck= -0.682    | Not Compliant |
| 2  | Log Normal        | Cs= 0.453<br>Ck= 3.368   | Cs= -0.116<br>Ck = -0.815 | Not meeting   |
| 3  | Gumbel            | Cs= 1.1396<br>Ck= 5.4002 | Cs= 0.46<br>Ck= -0.682    | Not Compliant |

(Source: Calculation Results, 2024)

Of the three types of distributions, none has the same skewness and kurtosis coefficient values as the data. Therefore, the distribution that matches the data is the Pearson III Log.

**Table 1. Recapitulation of Rainfall Calculation Results of Tolikara Design**

| Probabilities<br>in order<br>(P=1/T) | Anniversary<br>Period<br>(Years) | Distribution   |                       |                |                            |
|--------------------------------------|----------------------------------|----------------|-----------------------|----------------|----------------------------|
|                                      |                                  | Normal<br>(mm) | Log<br>Normal<br>(mm) | Gumbel<br>(mm) | Log<br>Pearson<br>III (mm) |
| 50%                                  | 2                                | 62.482         | 62.482                | 58.907         | 59.202                     |
| 20%                                  | 5                                | 80.751         | 62.584                | 78.138         | 65.375                     |
| 10%                                  | 10                               | 90.321         | 62.637                | 90.870         | 68.870                     |
| 4%                                   | 25                               | 100.543        | 62.694                | 106.957        | 72.995                     |
| 2%                                   | 50                               | 107.068        | 62.730                | 118.891        | 75.177                     |
| 1%                                   | 100                              | 112.941        | 62.763                | 130.738        | 77.479                     |

(Source: Calculation Results, 2024)

### 1) Flood Discharge Analysis

The design discharge is needed as input data in the analysis of the maximum water level on alternative intake locations in all rivers in Tolikara Regency (Ehalt Macedo et al., 2022; Medina et al., 2022). The method used to analyze the design discharge in this study is the Nakayasu Synthetic Unit Hydrograph Method.

**Table 2. River Data in Tolikara Regency**

| River Data |            |          |          |           |
|------------|------------|----------|----------|-----------|
| Regency    | River Flow | Long     | Elv Hulu | Elv Hilir |
| A          | B          | C        | D        | And       |
| Tolikara   | Holiday    | 339.0048 | 1919.238 | 1989.2461 |

(Source: Calculation Results, 2024)

### a) Nakayasu Unit Hydrograph Method

**Table 3. Recapitulation of Loma River Flood Discharge Calculation**

| No | Re-Period<br>( Year ) | Method               |
|----|-----------------------|----------------------|
|    |                       | HSS Nakayasu (m3/it) |
| 1  | 2                     | 5.642                |
| 2  | 5                     | 6.230                |
| 3  | 10                    | 6.563                |
| 4  | 25                    | 6.956                |
| 5  | 50                    | 7.164                |
| 6  | 100                   | 7.384                |

(Source: Calculation Results, 2024)

The following is a hydrographic chart of the Loma river

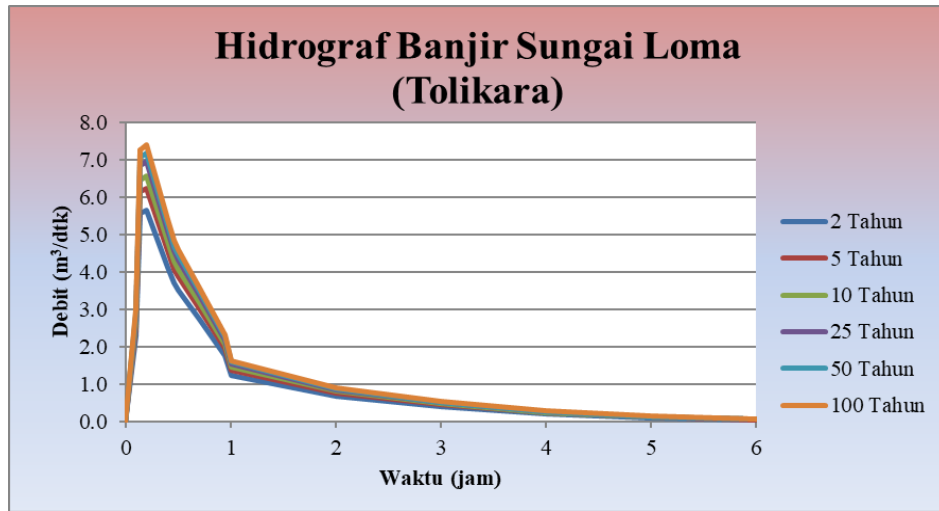
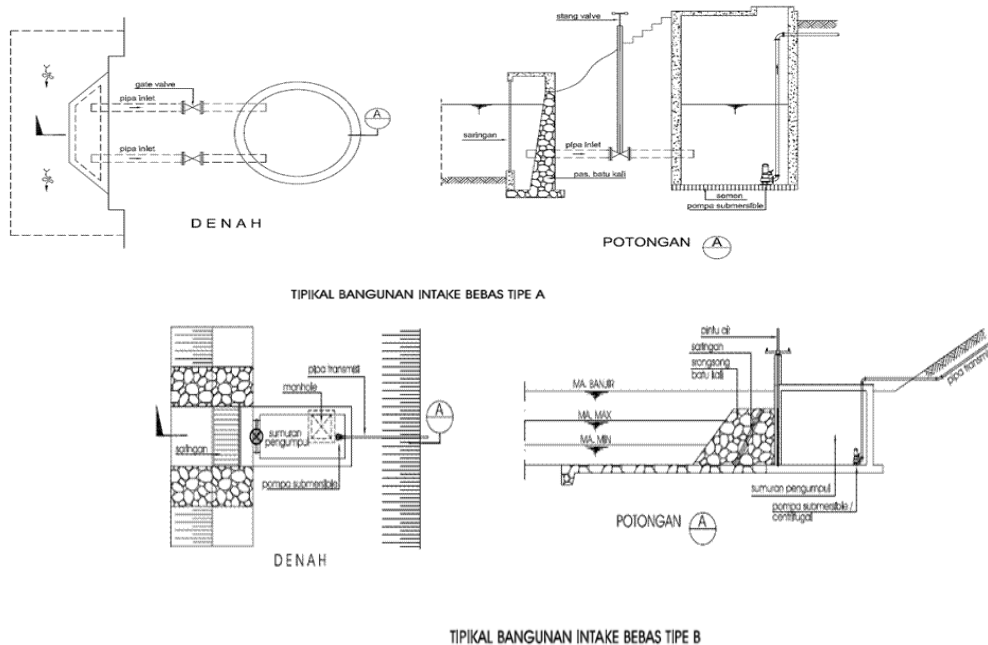

Figure 3. Flood Hydrograph for the Loma Tolikara River Intake

## 5. Intake Planning

### a. Intake Alternatives

With several considerations, especially because the river channel is used as a transportation channel and the cross-sectional geometry of the river is relatively deep, the type of intake that is suitable for use in the Loma River is *free intake*. Alternative types of *free intake* that can be considered are shown in the following figure.





(c) Intake Eksisting

**Figure 4. Alternative Free Intake Type**

**Table 4. Clean Water Discharge Capacity in Tolikara Regency**

| Regency City | Maximum Daily Needs (2045) | Water Availability (Q80) | Existing Capacity of the System (2022) | Additional Capacity |
|--------------|----------------------------|--------------------------|--|---------------------|
|              |                            |                          | LTR/s                                  |                     |
| Karubaga     | 51.272                     | 433.734                  | 0.000                                  | 51.272              |

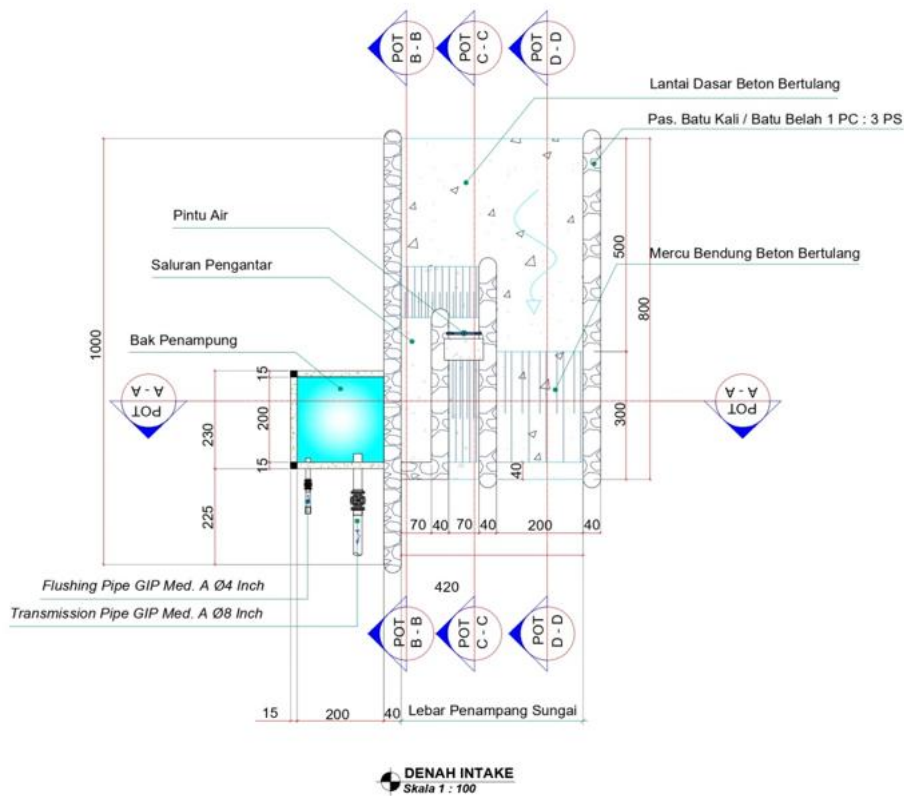

**Picture of the Loma River Intake Plan, Tolikara Regency**

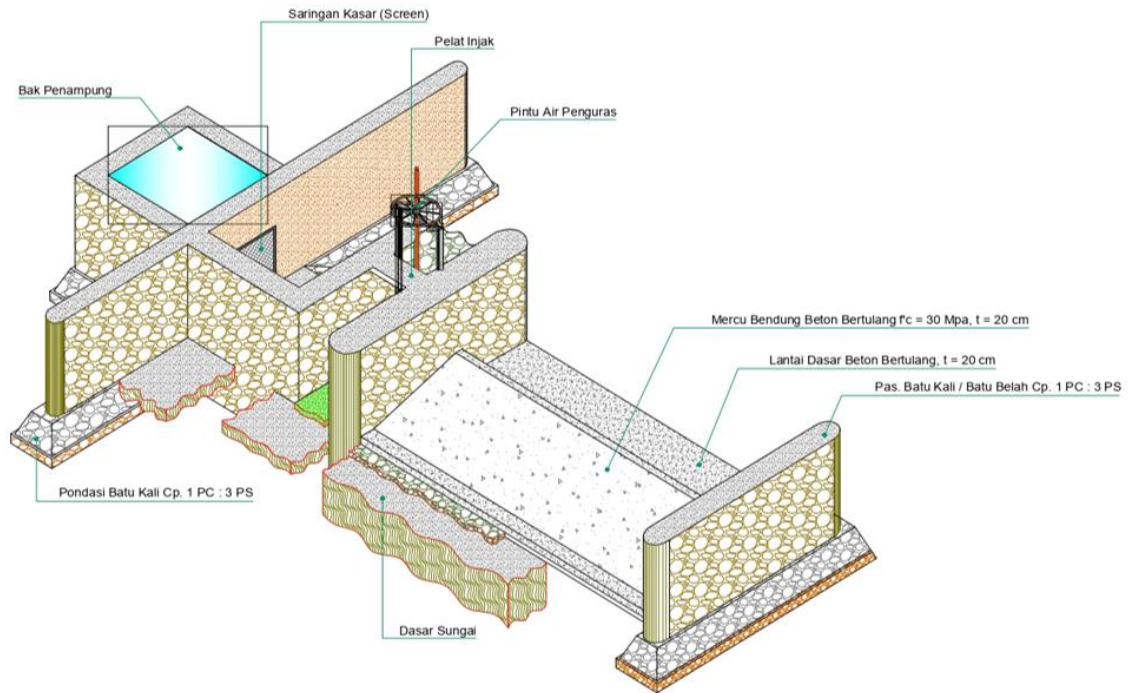

PERSPEKTIF INTAKE  
Skala 1 : 100

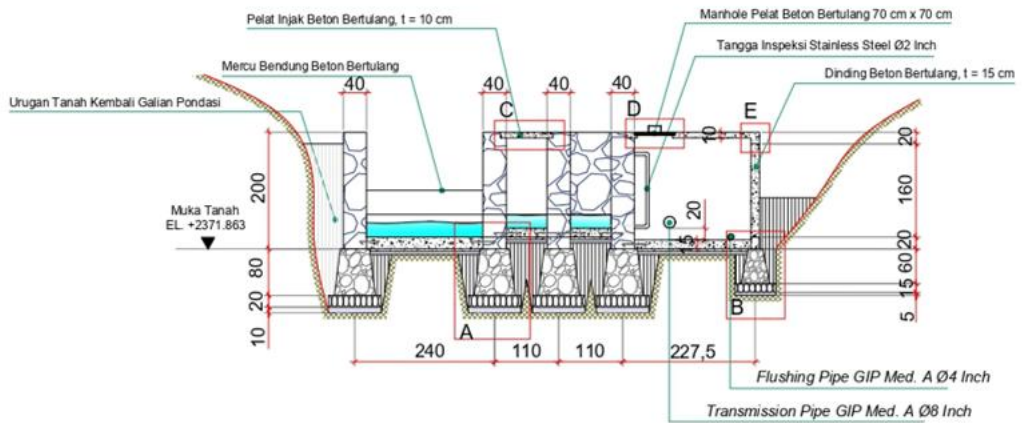

POTONGAN A - A  
Skala 1 : 75

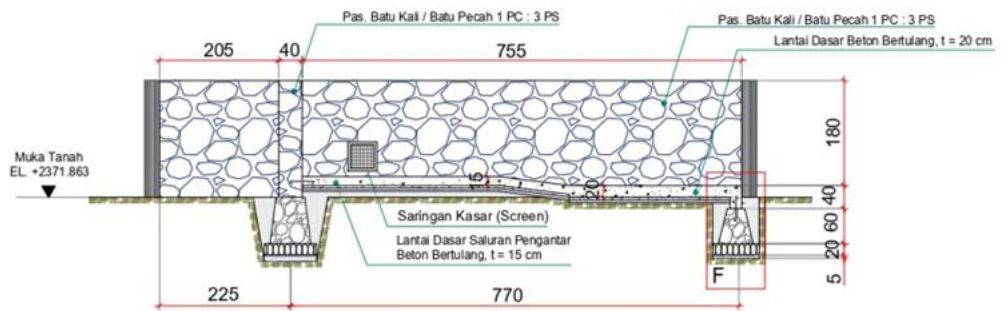

POTONGAN B - B  
Skala 1 : 75

# Intake Planning in Loma River, Tolikara Regency

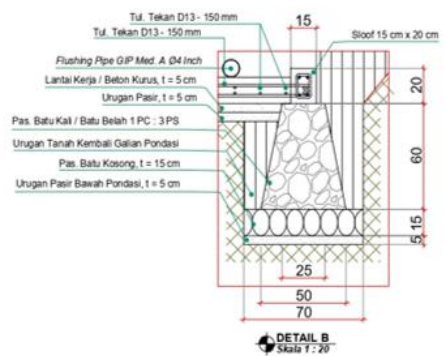
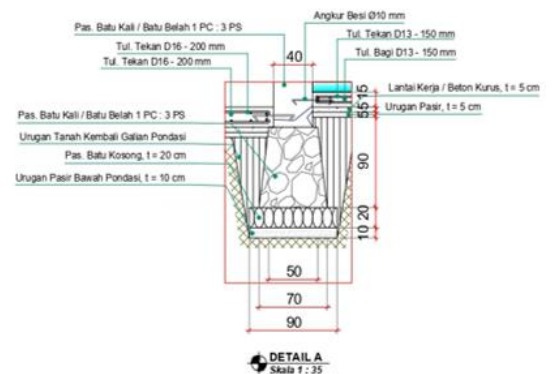
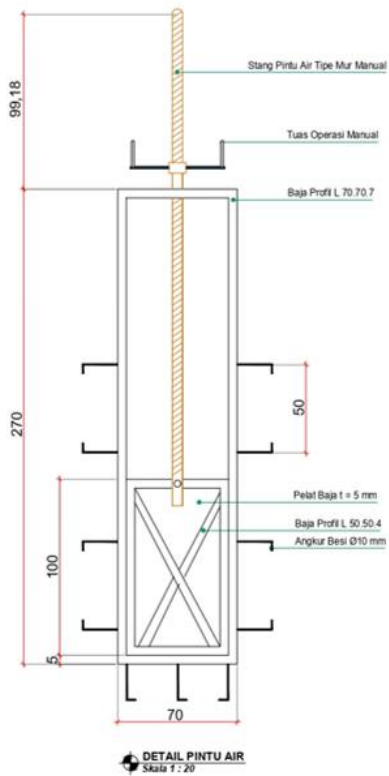
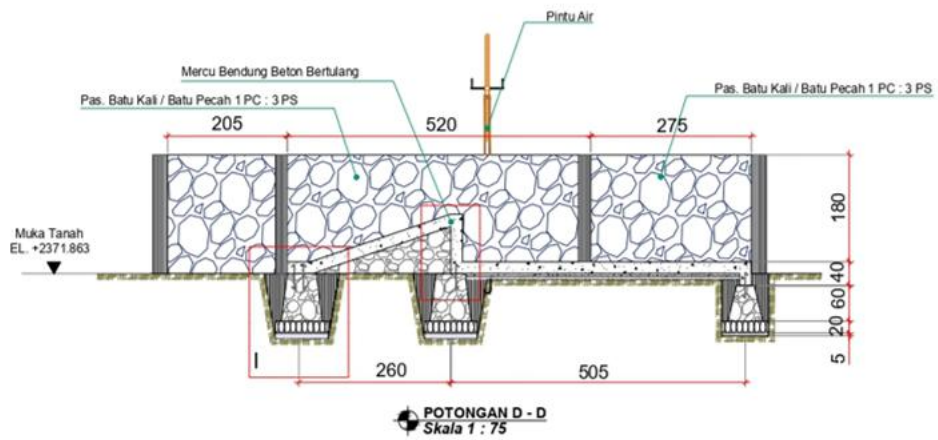
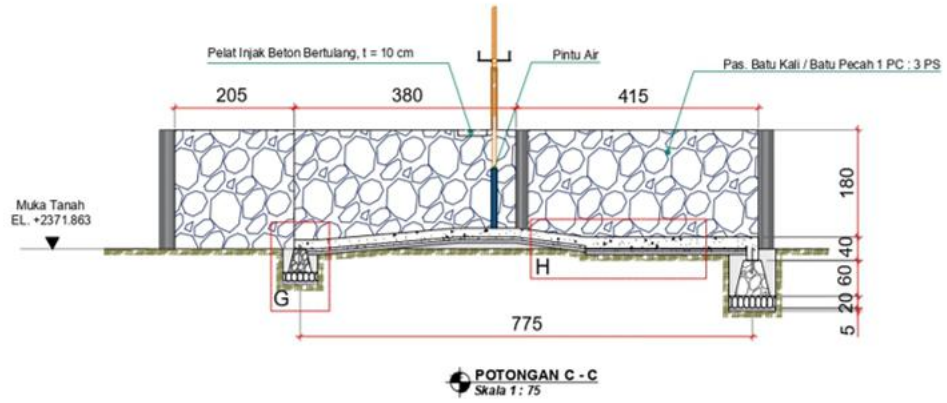

## Conclusion

Based on the description above, it can be concluded that the Intake Planning in the Loma River, Tolikara Regency is as follows: 1) The discharge of water availability in the Loma river, Tolikara Regency is 0.4332 m<sup>3</sup>/s. 2) The water demand in Tolikara Regency, especially in Karubaga District, is 51,272 liters/second (0.05 m<sup>3</sup>/s), for which it is necessary to build an intake in the Loma River in order to be able to drain water for the needs of the community. 3) The intake plan that will be built on the Loma river, Tolikara Regency, is to have a 2 x 2 x 2 meter reservoir.

## Bibliography

- Aboagye, B., Gyamfi, S., Ofori, E. A., & Djordjevic, S. (2022). Investigation into the impacts of design, installation, operation and maintenance issues on performance and degradation of installed solar photovoltaic (PV) systems. *Energy for Sustainable Development*, 66, 165–176. <https://doi.org/10.1016/j.esd.2021.12.003>
- BPS Papua. (2021). *Papua Province Statistical Data Report*. Badan Pusat Statistik. <https://papua.bps.go.id/id/publication/2021/02/26/aae8d17cd6f20e61a590d990/provinsi-papua-dalam-angka-2021.html>
- Darmasetiawan, M. (2004). *Teori dan Perencanaan Instalasi Pengolahan Air, Ekamitra Engineering*. Yayasan Suryono.
- Direktorat Jenderal Sumber Daya Air. (2013). *Standard Perencanaan Irigasi: Kriteria Perencanaan Bagian Bangunan Utama (Headworks)*. KP-02.240.
- Direktorat Jenderal Cipta Karya, Departemen Pekerjaan Umum. (2000). *Kriteria perencanaan sektor air bersih*. Jakarta: Direktorat Jenderal Cipta Karya.
- Ehalt Macedo, H., Lehner, B., Nicell, J., Grill, G., Li, J., Limtong, A., & Shakya, R. (2022). Distribution and characteristics of wastewater treatment plants within the global river network. *Earth System Science Data*, 14(2), 559–577. <https://doi.org/10.5194/essd-14-559-2022>
- Gabrielle, H., Kusumadewi, R. A., & Ratnaningsih. (2021). Optimisation of degreemont water treatment package on Kedung Halang water treatment plant, Bogor, West Java. *IOP Conference Series: Earth and Environmental Science*, 894(1), 012018. <https://doi.org/10.1088/1755-1315/894/1/012018>
- Gupta, D., Bhatt, S., Gupta, M., & Tosun, A. S. (2021). Future Smart Connected Communities to Fight COVID-19 Outbreak. *Internet of Things*, 13, 100342. <https://doi.org/10.1016/j.iot.2020.100342>
- Kılıç, Z. (2020). The importance of water and conscious use of water. *International Journal of Hydrology*, 4(5), 239–241. <https://doi.org/10.15406/ijh.2020.04.00250>
- Medina, M., Kaplan, D., Milbrandt, E. C., Tomasko, D., Huffaker, R., & Angelini, C. (2022). Nitrogen-enriched discharges from a highly managed watershed intensify

red tide (*Karenia brevis*) blooms in southwest Florida. *Science of The Total Environment*, 827, 154149. <https://doi.org/10.1016/j.scitotenv.2022.154149>

Müller Schmied, H., Cáceres, D., Eisner, S., Flörke, M., Herbert, C., Niemann, C., Peiris, T. A., Popat, E., Portmann, F. T., Reinecke, R., Schumacher, M., Shadkam, S., Telteu, C.-E., Trautmann, T., & Döll, P. (2021). The global water resources and use model WaterGAP v2.2d: model description and evaluation. *Geoscientific Model Development*, 14(2), 1037–1079. <https://doi.org/10.5194/gmd-14-1037-2021>

Pemerintah Pusat. (2004). *Undang-undang (UU) Nomor 7 Tahun 2004 tentang Sumber Daya Air*.

Pugel, P. M. (2015). Perencanaan sistem penyediaan air bersih di Kecamatan Belitang Kabupaten Sekadau Provinsi Kalimantan Barat. *Fakultas Teknik, Universitas Tanjungpura, Pontianak*.

Setyaninditha, M. A., Kadri, T., & Sejati, W. (2021). Studi Perencanaan Bangunan Intake Saluran Pembawa Air Baku Karian Barat. *Prosiding Seminar Intelektual Muda*, 2(2). <https://doi.org/10.25105/psia.v2i2.10312>

Silitonga, B. H. (2018). *Perencanaan hidrolis pintu pada bangunan pengambilan air (intake)*.

Silitonga, B. H. (2018). Perencanaan hidrolis pintu pada bangunan pengambilan air (intake).

WHO. (2022). *Guidelines for drinking-water quality: fourth edition incorporating the first and second addenda*. World Health Organization.