

## Location Selection and Design of Wasi River Intake Jayawijaya Regency

Davy I. Robert Jansen<sup>1\*</sup>, Dewi Ana Rusim<sup>2</sup>, Apolo Safanpo<sup>3</sup>, Firman Setiawan<sup>4</sup>,  
Alfian Adie Chandra<sup>5</sup>

Universitas Cenderawasih, Indonesia

Email: [dave.jansen04@gmail.com](mailto:dave.jansen04@gmail.com)<sup>1\*</sup>, [dewianarusim@yahoo.co.id](mailto:dewianarusim@yahoo.co.id)<sup>2</sup>,  
[safanpo2000@yahoo.com](mailto:safanpo2000@yahoo.com)<sup>3</sup>, [firmansetiawan1982@gmail.com](mailto:firmansetiawan1982@gmail.com)<sup>4</sup>,  
[alfiansipiluncen@gmail.com](mailto:alfiansipiluncen@gmail.com)<sup>5</sup>

Correspondence\*

### ABSTRACT

**Keywords:** Groundwater,  
Aquifer, Geology,  
Geomorphology, Elelim

The availability of clean water in Wamena City is a target for fulfilling local government development. In the suburbs, a Public Hydrant (HU) in the Sinakma area has been constructed to meet the community's clean water needs. The fulfillment of clean water needs for network distribution has also existed in Wamena City which was built in 2016 sourced from the Walesi River with the construction of a reservoir in the Napua area, but the distribution was disrupted because the Napua Intake was damaged by landslides. However, due to the condition of landslides and logging that are quite a lot in the upstream area, currently the intake does not function and affects the distribution of water in Wamena City. In 2023, an Intake and several reservoirs with the Wasi River water source in Walesi District have also been built, which are expected to meet the city's water needs. But in reality, the building has not been able to meet the needs of clean water because it cannot capture the flow of water properly.



### Introduction

Humans and living things need water, and even flora grows because of the presence of water. Indonesia has the potential for water availability to reach 690 billion cubic meters (m<sup>3</sup>) per year, but only about a quarter of that amount is utilized (Adhya Tirta Batam-ATB, January 29, 2015). This means that there are still many that have not been utilized. Water is vital in life, and therefore, it needs to be cared for and conserved.

The availability of clean water in Wamena City is a target for fulfilling local government development. In the suburbs, there has been the construction of a Public Hydrant (HU) in the Sinakma area to meet the community's clean water needs. The fulfillment of clean water needs for network distribution has also existed in Wamena City, which was built in 2016 sourced from the Walesi River with the construction of a reservoir in the Napua area, but the distribution was disrupted because a landslide

damaged the Napua Intake. However, due to the condition of landslides and logging that are quite a lot in the upstream area, currently the intake does not function and affects the distribution of water in Wamena City. In 2023, an Intake and several reservoirs with the Wasi River water source in Walesi District were also built, which are expected to meet the city's water needs. But in reality, the building has not been able to meet the need for clean water because it cannot properly capture the water flow.

In this study, the location and design of the Wasi River intake in Jayawijaya Regency will be selected so that the people of Jayawijaya Regency meet the community's needs for clean water.

The objectives of this study are:

The purpose of this research is to select the location and design of the intake on the Wasi River, Jayawijaya Regency in order to meet the water needs of the community.

## **Method**

The location of this research was carried out in Jayawijaya Regency, Wamena District on one of its rivers, namely the Wasi River. The wasi river is located on 138° 53' 56.39" East Longitude 4° 9' 16" south latitude.

The data collection methods that will be carried out in this study are:

1. Data primer
  - a. Preparation stage with the mobilization of equipment and materials teams,
  - b. Inventory of technical and non-technical data or information that supports the implementation of research.
  - c. Field review of the research location,
  - d. Field data collection needed for analysis such as hydrological data, topography, soil investigation and others.

2. Data seconds

Secondary data is literature study data taken from several previous studies and there is also Jayawijaya Regency Population data, Climatology data from the Jayawijaya Regency Meteorological Station for 10 years (2013-2022) which includes: monthly rainfall, maximum daily rainfall, air temperature, relative humidity, solar irradiation and wind speed

## Results and Discussion

### Population Projections

The population growth rate is calculated from population growth data of all districts in the mountainous province of Papua based on BPS data from Papua Province in 2021.

**Tabel 1. Population Growth Rate of Mountainous Papua Province**

No	Regency/City	District	Total Population in 2022 (Soul)	Population Growth Ratio (%)
1	Jayawijaya	Wamena	65766	1.85
2	Lanny Jaya	Tiom	11013	1.56
3	Tolikara	Karubaga	18003	1.85
4	Mamberamo Tengah	Kobakma	13844	1.25
5	Yalomo	Elelim	16675	1.85
6	Nduga	Kenyam	6264	1.74
7	Yahukimo	Dekai	17963	1.85
8	Bintang Mountains	Oksibil	6475	0.52

#### 1) Geometric Method,

The results of the Population Growth Calculation using the Geometric method can be obtained that the number of people in each district can be projected up to 25 years and can be seen in the following table:

**Table 2 Recapitulation of Population Projections for the Next 25 Years of Mountainous Papua Province Using the Geometric Method**

Tahun	n	Jumlah Penduduk (Jiwa)							
		Wamena	Tiom	Karubaga	Kobakma	Elelim	Dekai	Oksibil	Kenyam
2020	0	65766	11013	17676	13504	16675	17316	6408	6157
2025	5	72079	11899	19373	14369	18276	18978	6576	6712
2030	10	78997	12857	21232	15290	20030	20800	6749	7316
2035	15	86580	13891	23270	16270	21952	22796	6926	7975
2040	20	94890	15009	25504	17313	24059	24984	7108	8694
2045	15	103999	16217	27952	18422	26369	27383	7295	9477

### Projected Water Needs

The determination of household water use levels is adjusted to the city category based on the Clean Water SK-SNI.

**Table 3 Household Water Usage Levels by City Category**

No	City Category	Total Population	System	Water Usage
1	Metropolitan Cities	> 1.000.000	Non-Standard	190
2	Big City	500.000 – 1.000.000	Non-Standard	170
3	Medium City	100.000 – 500.000	Non-Standard	150
4	Small Town	20.000 – 100.000	BNA Standard	130

No	City Category	Total Population	System	Water Usage
5	Cities and Districts	< 20.000	IKK Standards	100
6	Growth Center City	< 3.000	DPP Standards	30

Table 4 shows the criteria used and the results of calculating the full projected water demand.

**Table 4. Service Criteria and Water Usage Levels**

No	Description / criteria	Year						
		2015	2020	2025	2030	2035	2040	2045
1	Population Served (%)	60	65	70	75	80	85	90
2	SR Percentage	60	62,5	65	67,5	70	72,5	75
	HU Percentage	40	37,5	35	32,5	30	27,5	25
3	Water consumption (liters/person/day)							
	- House Samb (SR)	100	105	110	115	120	125	130
	- General Hydrants (HU)	30	30	30	30	30	30	30
4	Non-Domestic Expenses (%)	20	22,5	25	27,5	30	30	30
5	Water Loss (%)	20	20	20	20	20	20	20
6	Max Daily Factor	1,1	1,1	1,1	1,1	1,1	1,1	1,1
7	Peak Hour Factor	1,5	1,5	1,5	1,5	1,5	1,5	1,5

**Table 1 Projection of Jayawijaya Regency's Water Needs until 2045**

No	Description / Criteria	Unit	Projected Year					
			2020	2025	2030	2035	2040	2045
1	Household Needs (Domestic)							
	- Total Population	(soul)	65766	72079	78997	86580	94890	103999
	- Total of Population Served	(soul)	39460	46851	55298	64935	75912	88399
	- Served with SR	(soul)	23676	29282	35944	43831	53139	64089
	- Served through HU	(soul)	15784	17569	19354	21104	22774	24310
	- SR Needs	(m <sup>3</sup> /day)	2368	3075	3954	5041	6377	8011
	- HU Needs	(m <sup>3</sup> /day)	474	527	581	633	683	729
	- Total of household needs	(m <sup>3</sup> /day)	2841	3602	4534	5674	7060	8740
2	Non-Domestic Needs	(m <sup>3</sup> /day)	710	1046	1511	2152	3026	3746
3	Total (1+2)	(m <sup>3</sup> /day)	3551	4647	6046	7826	10085	12486
4	Water Loss	(m <sup>3</sup> /day)	710	929	1209	1565	2017	2497
5	Average Daily Needs		4262	5577	7255	9391	12103	14984
6	Maximum Daily Needs	(m <sup>3</sup> /day)	4688	6134	7981	10330	13313	16482
		(lt/sec)	54.26	71.00	92.37	119.56	154.08	190.76

No	Description / Criteria	Unit	Projected Year					
			2020	2025	2030	2035	2040	2045
		(m <sup>3</sup> /Sec)	0.05	0.07	0.09	0.12	0.15	0.19
		(lt/day)	4,687,800	6,134,474	7,980,614	10,330,023	13,312,846	16,481,949
7	Peak Hour Needs	(m <sup>3</sup> /day)	7032	9202	11971	15495	19969	24723
		(lt/second)	81.39	106.50	138.55	179.34	231.13	286.14

### Reliable Debit

The results of the calculation of discharge with 80% reliability (Q80) in all rivers in the Mountainous Papua Province are shown in sequence in the following Table 6.

**Table 6 Results of Reliable Discharge Calculation on the Wasi River in Mountainous Papua Province,**

No	Month	Water Availability, Q <sub>80</sub>
		(m <sup>3</sup> /s) S. Wasi
1	Jan	5.9595
2	Feb	6.0603
3	Mar	6.0880
4	Apr	6.1412
5	Mei	6.0396
6	Jun	6.1452
7	Jul	6.1244
8	Aug	6.0095
9	Sep	5.9378
10	Oct	5.9323
11	Nov	5.9355
12	Des	6.0417

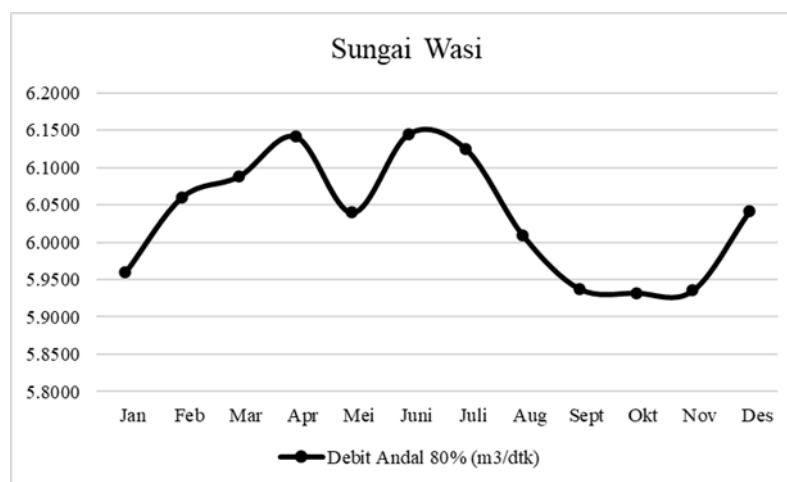

**Figure 1 Reliable Discharge (Q80) of the Wasi River**

### Water Balance

The results of the water demand projection show that water demand is much smaller than water availability in every river in Jayawijaya Regency. For clarity, Table 7 and Figure 2 below show the comparison between water demand and water availability in Jayawijaya Regency.

**Table 7. Results of Jayawijaya Reliable Debit Calculation**

No	Month	Water Availability,	Water	Surplus (m <sup>3</sup> /s)
		Q <sub>80</sub> (m <sup>3</sup> /s) S. Wasi	Requirements (m <sup>3</sup> /s)	
1	Jan	5.9595	0.04	5.9213
2	Feb	6.0603	0.04	6.0222
3	Mar	6.0880	0.04	6.0498
4	Apr	6.1412	0.04	6.1030
5	Mei	6.0396	0.04	6.0015
6	Jun	6.1452	0.04	6.1070
7	Jul	6.1244	0.04	6.0862
8	Aug	6.0095	0.04	5.9714
9	Sep	5.9378	0.04	5.8997
10	Oct	5.9323	0.04	5.8941
11	Nov	5.9355	0.04	5.8974
12	Des	6.0417	0.04	6.0035

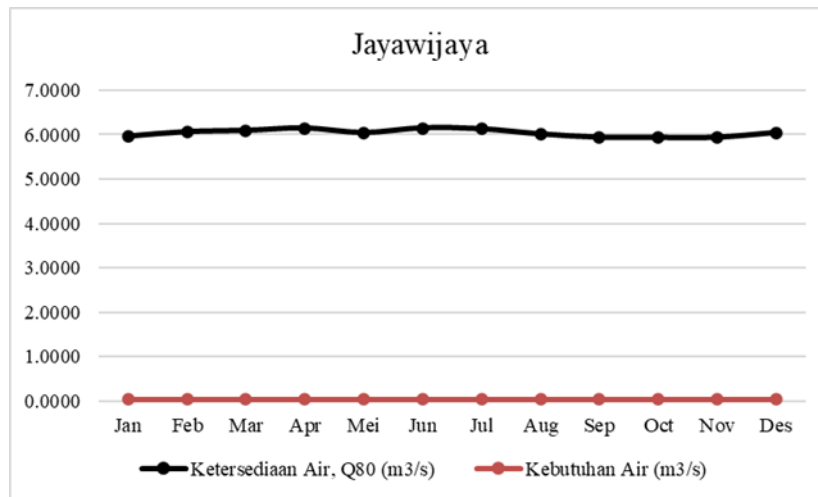

**Figure 2 Comparison of Water Availability and Water Needs in Jayawijaya**

### Rainfall Analysis Design

The methods used to analyze the draft rainfall in this study are the Gumbel method, the Pearson Log Method Type III and the Normal Log Method. To determine which method is the most suitable, a distribution suitability test is carried out with the Chi-Square test and the Smirnov-Kolmogorof test.

#### 1) The Gumbel Method

The empirical equation for the Gumbel Type I distribution is as follows:

**Table 8 Y<sub>T</sub> Values for Multiple Re-periods**

Re-Period, <i>T</i> (years)	<i>Y<sub>T</sub></i>
2	0.3665
5	1.4999
10	2.2502

Re-Period, $T$ (years)	$Y_T$
20	2.9702
25	3.1985
50	3.9019
100	4.6001
200	5.2958

**Table 9 Reduction of Average Value,  $Y_n$**

n	Values $Y_n$									
	0	1	2	3	4	5	6	7	8	9
10	0.4952	0.4996	0.5035	0.5070	0.5100	0.5125	0.5157	0.5181	0.5202	0.5220
20	0.5236	0.5252	0.5268	0.5283	0.5296	0.5309	0.5320	0.5332	0.5343	0.5353
30	0.5362	0.5371	0.5380	0.5388	0.5396	0.5402	0.5410	0.5418	0.5424	0.5430
40	0.5436	0.5442	0.5448	0.5453	0.5458	0.5463	0.5468	0.5473	0.5477	0.5481
50	0.5485	0.5489	0.5493	0.5497	0.5501	0.5504	0.5508	0.5511	0.5515	0.5518
60	0.5521	0.5524	0.5527	0.5530	0.5533	0.5535	0.5538	0.5540	0.5543	0.5545
70	0.5548	0.5550	0.5552	0.5555	0.5557	0.5559	0.5561	0.5563	0.5565	0.5567
80	0.5568	0.5570	0.5572	0.5574	0.5576	0.5578	0.5580	0.5581	0.5583	0.5585
90	0.5586	0.5587	0.5589	0.5591	0.5592	0.5593	0.5595	0.5596	0.5598	0.5599
100	0.5600									

**Table 10. Reduction of Deviation Standards,  $S_n$**

n	Values $S_n$									
	0	1	2	3	4	5	6	7	8	9
10	0.9436	0.9697	0.9833	0.9971	1.0095	1.0206	1.0316	1.0411	1.0493	1.0563
20	1.0628	1.0696	1.0754	1.0811	1.0864	1.0915	1.0961	1.1004	1.1047	1.1086
30	1.1124	1.1159	1.1193	1.1226	1.1255	1.1285	1.1313	1.1339	1.1363	1.1388
40	1.1413	1.1436	1.1458	1.1480	1.1499	1.1519	1.1538	1.1557	1.1574	1.1590
50	1.1607	1.1623	1.1638	1.1653	1.1667	1.1681	1.1695	1.1708	1.1721	1.1733
60	1.1747	1.1759	1.1770	1.1782	1.1793	1.1803	1.1814	1.1824	1.1834	1.1844
70	1.1854	1.1863	1.1873	1.1881	1.1890	1.1898	1.1907	1.1915	1.1923	1.1930
80	1.1938	1.1945	1.1953	1.1960	1.1967	1.1973	1.1980	1.1987	1.1994	1.2001
90	1.2007	1.2013	1.2020	1.2026	1.2032	1.2038	1.2044	1.2049	1.2055	1.2060
100	1.2065									

The results of the calculation of the rainfall of the design using the Gumbel method are as follows:

**Table 11. Calculation of Statistical Parameters of the Jayawijaya Gumbel Method**

No	Year	Rmax (mm)	$(X' - \bar{X})$	$(X' - \bar{X})^2$	$(X' - \bar{X})^3$
1	2012	99.70	37.218	1385.193	51554.367
2	2013	54.40	-8.082	65.316	-527.870
3	2014	33.20	-29.282	857.425	-25106.959

4	2015	61.10	-1.382	1.909	-2.638
5	2016	40.30	-22.182	492.033	-10914.188
6	2017	39.00	-23.482	551.396	-12947.776
7	2018	65.30	2.818	7.942	22.382
8	2019	93.20	30.718	943.607	28985.882
9	2020	57.20	-5.282	27.898	-147.350
10	2021	61.50	-0.982	0.964	-0.946
11	2022	82.40	19.918	396.734	7902.219
Total		687	0.000	4730.416	38817.123
Average		62.482	0.000	430.038	3528.829
Standard Deviation			21.750		
Cv			0.34809359		
Cs			0.461131154		
Ck			-0.682206651		

## 2) Pearson Log Method Type III

The distribution equation of the Pearson Log Type III can be written as follows:

**Table 12 K-Values for Pearson Type III Log Distribution**

Coefficient Skewness $G$	Re-Period, $T$ (years)					
	2	5	10	25	50	100
	Chance (%)					
	50	20	10	4	2	1
3.0	-0.396	0.420	1.180	2.278	3.152	4.051
2.8	-0.384	0.460	1.210	2.275	3.114	3.973
2.6	-0.368	0.499	1.238	2.267	3.071	3.889
2.4	-0.351	0.537	1.262	2.256	3.023	3.800
2.2	-0.330	0.574	1.284	2.240	2.970	3.705
2.0	-0.307	0.609	1.302	2.219	2.912	3.605
1.8	-0.282	0.643	1.318	2.193	2.848	3.499
1.6	-0.254	0.675	1.329	2.163	2.780	3.388
1.4	-0.225	0.705	1.337	2.128	2.706	3.271
1.2	-0.195	0.732	1.340	2.087	2.626	3.149
1.0	-0.164	0.758	1.340	2.043	2.542	3.022
0.9	-0.148	0.769	1.339	2.018	2.498	2.957
0.8	-0.132	0.780	1.336	1.993	2.453	2.891
0.7	-0.116	0.790	1.333	1.967	2.407	2.824
0.6	-0.099	0.800	1.328	1.939	2.359	2.755
0.5	-0.083	0.808	1.323	1.910	2.311	2.686
0.4	-0.066	0.816	1.317	1.880	2.261	2.615
0.3	-0.050	0.824	1.309	1.849	2.211	2.544
0.2	-0.033	0.830	1.301	1.818	2.159	2.472
0.1	-0.017	0.836	1.292	1.785	2.107	2.400
0.0	0.000	0.842	1.282	1.751	2.054	2.326

The calculation of statistical parameters and design rainfall using the Pearson Type III Log method is shown in Table 13 below.

**Table 13. Calculation of Statistical Parameters of the Jayawijaya Type III Pearson Log Method**

No	Year	Pmax (mm)	lnx	(lnX - lnX') <sup>2</sup>	(lnX - lnX') <sup>3</sup>
1	2012	99.7	4.602	0.274	0.144
2	2013	54.4	3.996	0.007	-0.001
3	2014	33.2	3.503	0.332	-0.191
4	2015	61.1	4.113	0.001	0.000
5	2016	40.3	3.696	0.146	-0.056
6	2017	39.0	3.664	0.172	-0.071
7	2018	65.3	4.179	0.010	0.001
8	2019	93.2	4.535	0.208	0.095
9	2020	57.2	4.047	0.001	0.000
10	2021	61.5	4.119	0.002	0.000
11	2022	82.4	4.412	0.111	0.037
Total		687	44.864	1.264	-0.043
Average		62.482	4.079	0.115	-0.004
Standard Deviation			0.121		
Csy			-0.116		

**3) Two-Parameter Normal Log Method**

The log-normal distribution of two parameters has the following transformation equations:

**Table 14 Frequency Factor (K) Value as a Function of Cv Value,**

Coefficient Variations (CV)	Cumulative Chance P (%) : P(X<=X)					
	50	80	90	95	98	99
	Anniversary Period (Years)					
	2	5	10	20	50	100
0.05	-0.0250	0.8334	1.2965	1.6863	2.1341	2.4570
0.10	-0.0496	0.8222	1.3078	1.7247	2.2130	2.5489
0.15	-0.0738	0.8085	1.3156	1.7598	2.2899	2.2607
0.20	-0.0971	0.7926	1.3200	1.7911	2.3640	2.7716
0.25	-0.1194	0.7746	1.3209	1.8183	2.4318	2.8805
0.30	-0.1406	0.7647	1.3183	1.8414	2.5015	2.9866
0.35	-0.1604	0.7333	1.3126	1.8602	2.5638	3.0890
0.40	-0.1788	0.7100	1.3037	1.8746	2.6212	3.1870
0.45	-0.1957	0.6870	1.2920	1.8848	2.6731	3.2799

Coefficient Variations (CV)	Cumulative Chance P (%) : $P(X \leq X)$					
	50	80	90	95	98	99
	Anniversary Period (Years)					
	2	5	10	20	50	100
0.50	-0.2111	0.6626	1.2778	1.8909	2.7202	3.3673
0.55	-0.2251	0.6379	1.2613	1.8931	2.7613	3.4488
0.60	-0.2375	0.6129	1.2428	1.8915	2.7971	3.5211
0.65	-0.2185	0.5879	1.2226	1.8866	2.8279	3.3930
0.70	-0.2582	0.5631	1.2011	1.8786	2.8532	3.3663
0.75	-0.2667	0.5387	1.1784	1.8677	2.8735	3.7118
0.80	-0.2739	0.5118	1.1548	1.8543	2.8891	3.7617
0.85	-0.2801	0.4914	1.1306	1.8388	2.9002	3.8056
0.90	-0.2852	0.4686	1.1060	1.8212	2.9071	3.8137
0.95	-0.2895	0.4466	1.0810	1.8021	2.9103	3.8762
1.00	-0.2929	0.4254	1.0560	1.7815	2.9098	3.9035

**Table 15 Calculation of Jayawijaya Normal Log Distribution Statistical Parameters**

No	Year	Pmax (mm)	lnx	$(\ln X - \ln X')^2$	$(\ln X - \ln X')^3$
1	2012	99.7	4.602	0.2741381	0.1435337
2	2013	54.4	3.996	0.0067601	-0.0005558
3	2014	33.2	3.503	0.3318150	-0.1911367
4	2015	61.1	4.113	0.0011511	0.0000391
5	2016	40.3	3.696	0.1461015	-0.0558447
6	2017	39.0	3.664	0.1722433	-0.0714848
7	2018	65.3	4.179	0.0100818	0.0010123
8	2019	93.2	4.535	0.2080856	0.0949212
9	2020	57.2	4.047	0.0010259	-0.0000329
10	2021	61.5	4.119	0.0016365	0.0000662
11	2022	82.4	4.412	0.1108901	0.0369266
Total		687	44.864	1.2639290	-0.0425558
Average		62.482	4.079	0.1149026	-0.0038687
Standard Deviation			0.121155328		
Csy			-0.116		
Ck			-0.815		

#### 4) Recapitulation of Distribution Conformity Test Results

**Table 16. Provisions for Distribution Conformity Test Results**

No	Distribution Type	Condition	Calculation Results	Conclusion
1	Normal	$C_s = 0$ $C_k = 3$	$C_s = 0.46$ $C_k = -0.682$	Not Compliant

No	Distribution Type	Condition	Calculation Results	Conclusion
2	Log Normal	Cs= 0.453	Cs= -0.116	Not Compliant
		Ck= 3.368	Ck = -0.815	
3	Gumbel	Cs= 1.1396	Cs= 0.46	Not Compliant
		Ck= 5.4002	Ck= -0.682	

Based on these three statistical parameters, none of the three types of distribution has the same skewness and kurtosis coefficient values as the data. Therefore, the distribution that matches the data is the Pearson III Log.

**Table 17. Recapitulation of the Results of Rainfall Calculation of Jayawijaya Design**

Probabilities in order (P=1/T)	Anniversary Period (Years)	Distribution			
		Normal (mm)	Log Normal (mm)	Gumbel (mm)	Log Pearson III (mm)
50%	2	62.482	62.482	58.907	59.202
20%	5	80.751	62.584	78.138	65.375
10%	10	90.321	62.637	90.870	68.870
4%	25	100.543	62.694	106.957	72.995
2%	50	107.068	62.730	118.891	75.177
1%	100	112.941	62.763	130.738	77.479

### Flood Discharge Analysis

The method used to analyze the design discharge in this study is the Nakayasu Synthetic Unit Hydrograph Method.

**Table 18. Data of the Wasi River in Jayawijaya Regency,**

River Data				
Regency	River Flow	Long	Elv Upstream	Elv Downstream
A	B	C	D	E
Jayawijaya	Wasi	6076.48	3169.91	2116.36

#### 1) Nakayasu Unit Hydrograph Method

Using the calculation of rainfall, the recapitulation of the calculation of the Hydrograph coordinates of the nakayasu unit is calculated as follows:

**Table 19. Recapitulation of Flood Discharge Calculation with Nakayasu Method and Existing Flood Discharge,**

No	Re-Period	Method
	( Year )	HSS Nakayasu ( m <sup>3</sup> / det )
1	2	25.688
2	5	28.366
3	10	29.883
4	25	31.673
5	50	32.619
6	100	33.618

The following is a hydrograph graph of the Wasi river in Jayawijaya Regency.

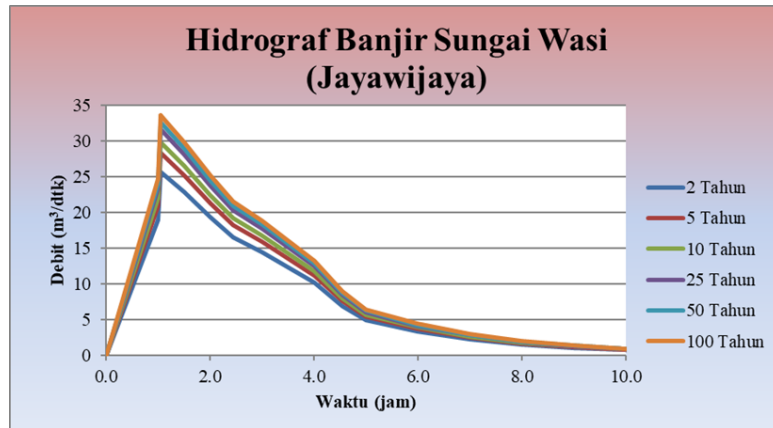

Figure 4. Flood Hydrograph for Wasi Jayawijaya River Intake

### Intake Design

#### 1) Intake

The considerations made because the channel from the Wasi River is also used as a transportation channel and the condition of the river cross-section is quite deep. Based on data analysis and competition regarding the existence in the field, the type of Intake used in the design of the river is Free Intake.

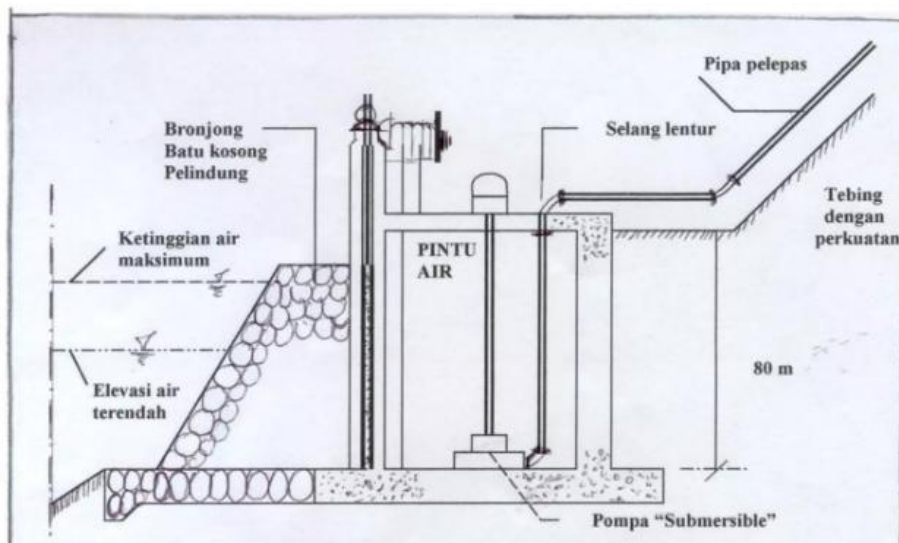
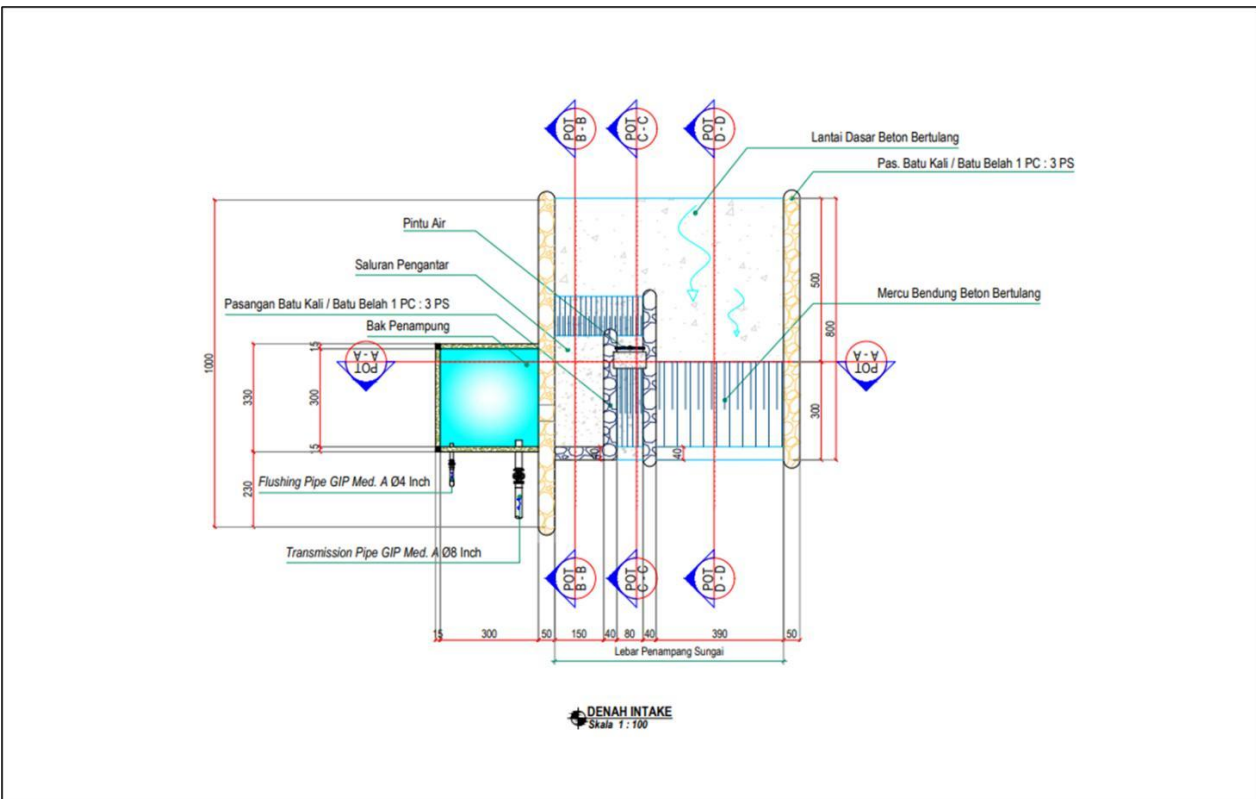
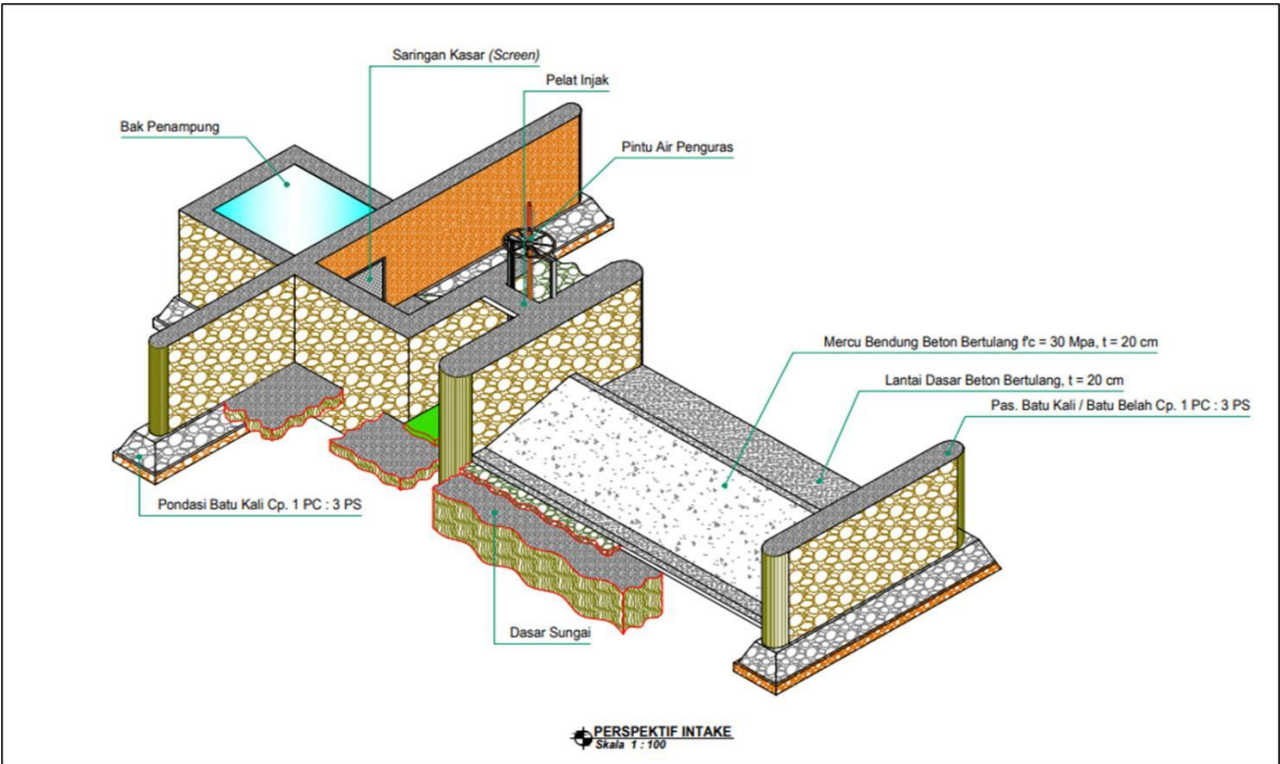

Figure 5. Free Intake Type

Table 20. Clean Water Discharge Capacity in Jayawijaya Regency

No	Regency City	Maximum Daily Needs (2045)	Water Availability (Q80)	Existing Capacity of the System (2022)	Additional Capacity
				LTR/DTK	
1	Wamena	190.763	72414.985	23.333	167.430

**Figure of the Wasi River Intake Plan of Jayawijaya Regency**



**Picture of the Wasi River Intake Cut Plan of Jayawijaya Regency**

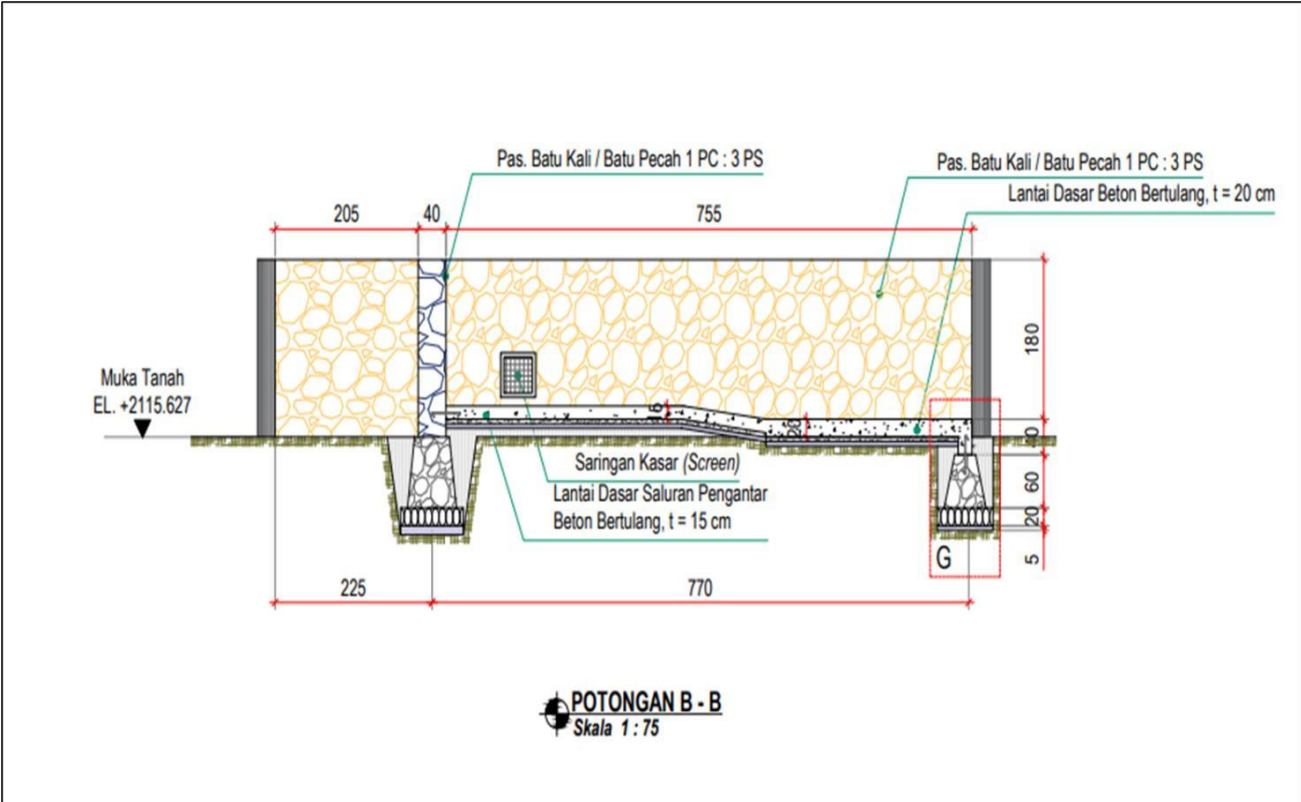
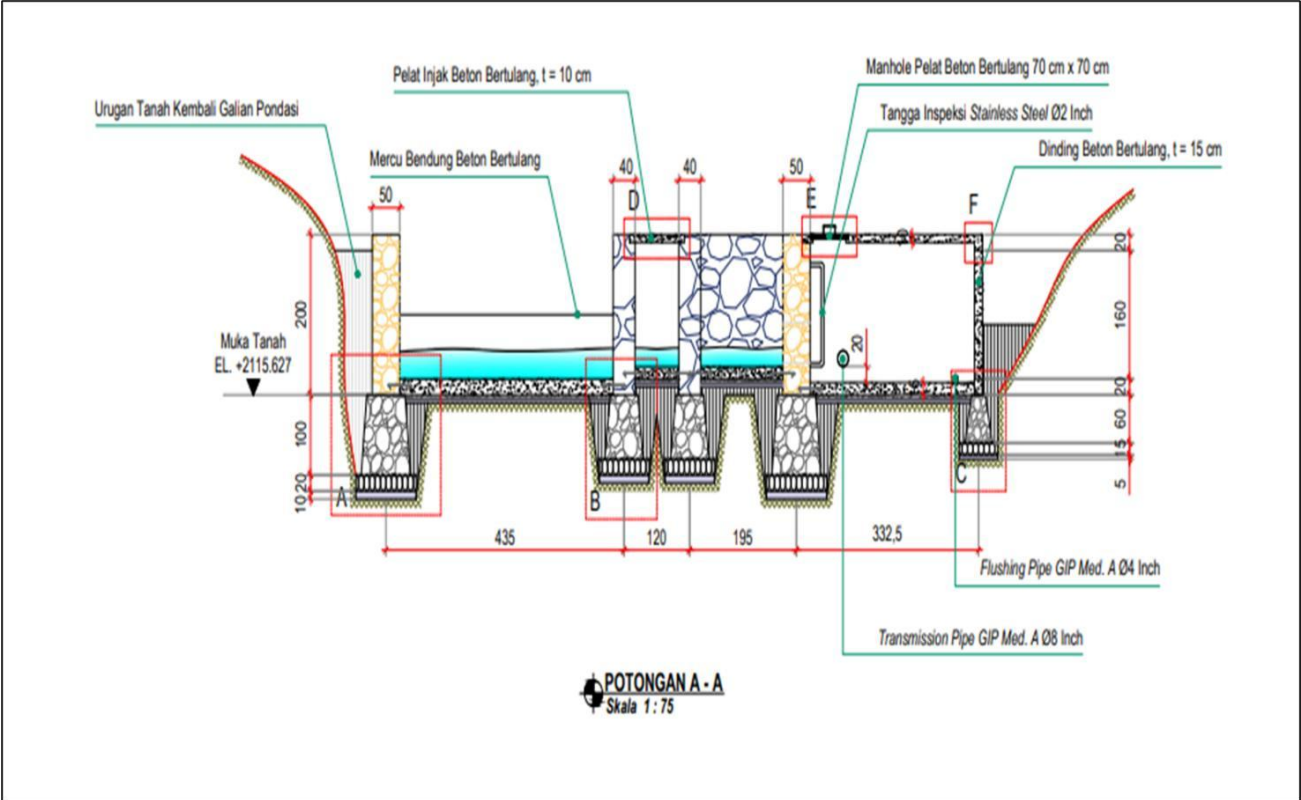

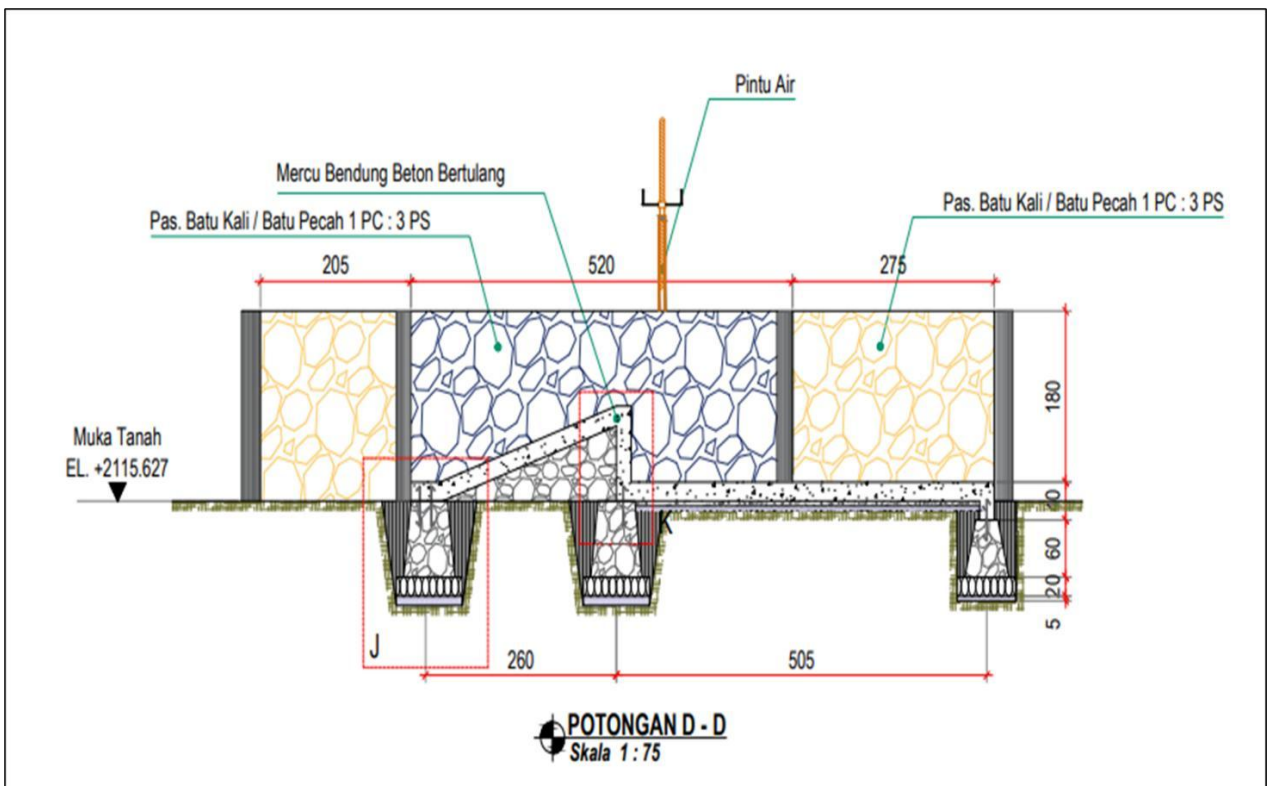
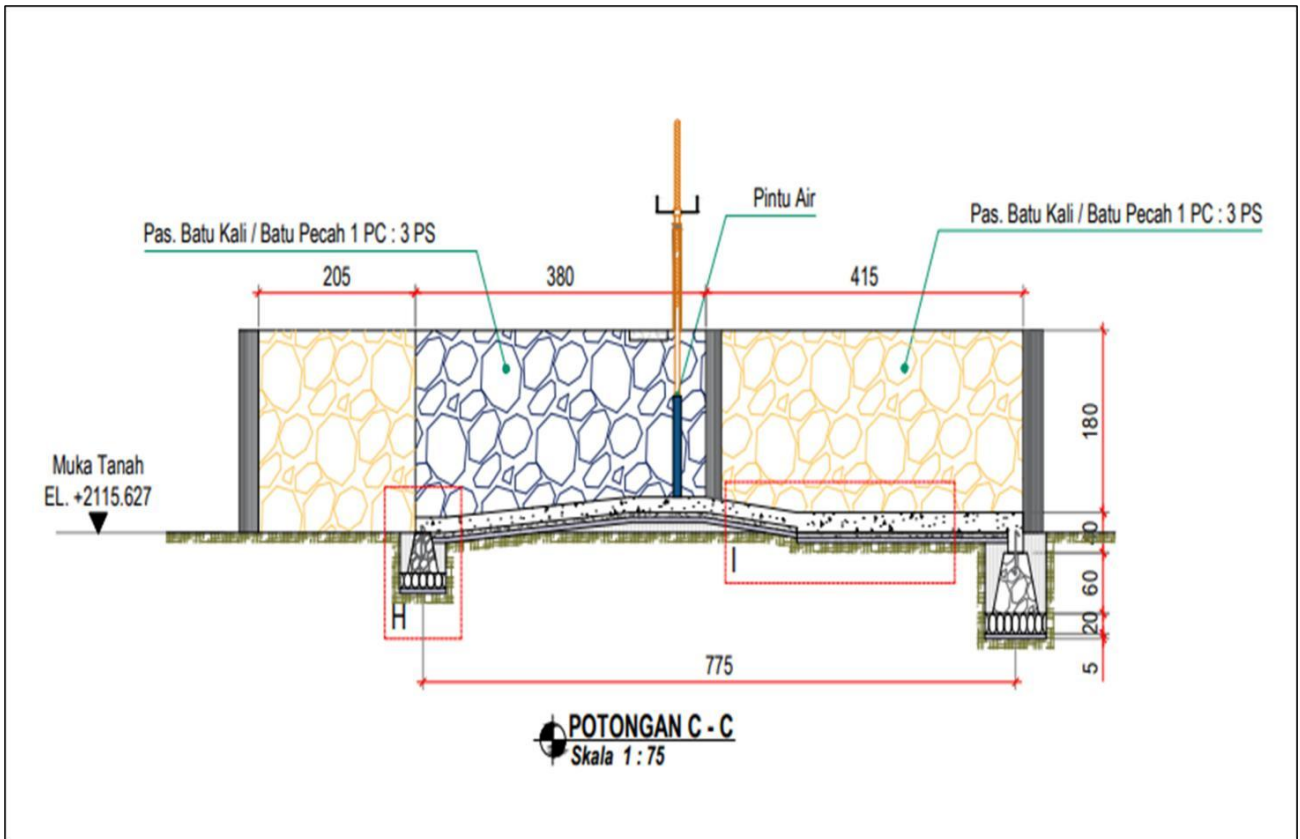

## Detail Drawings of Floodgates and Intake Foundation Details

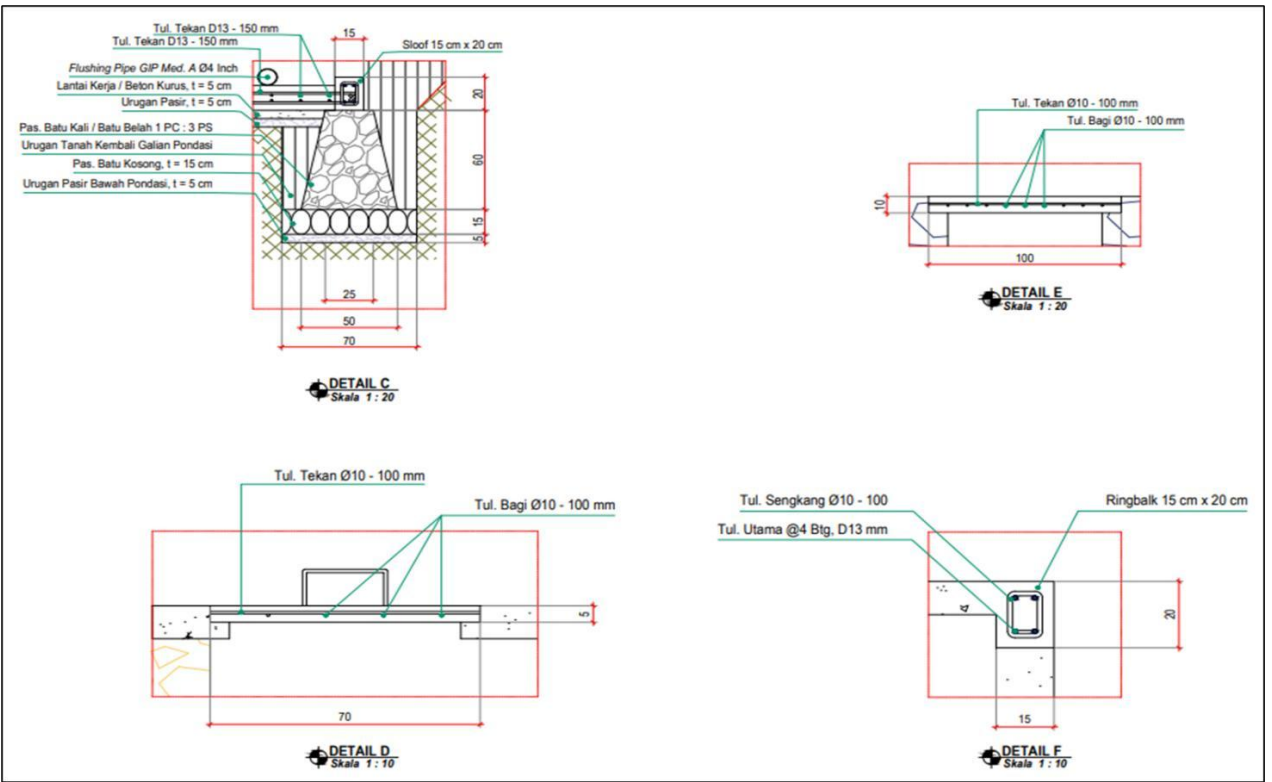
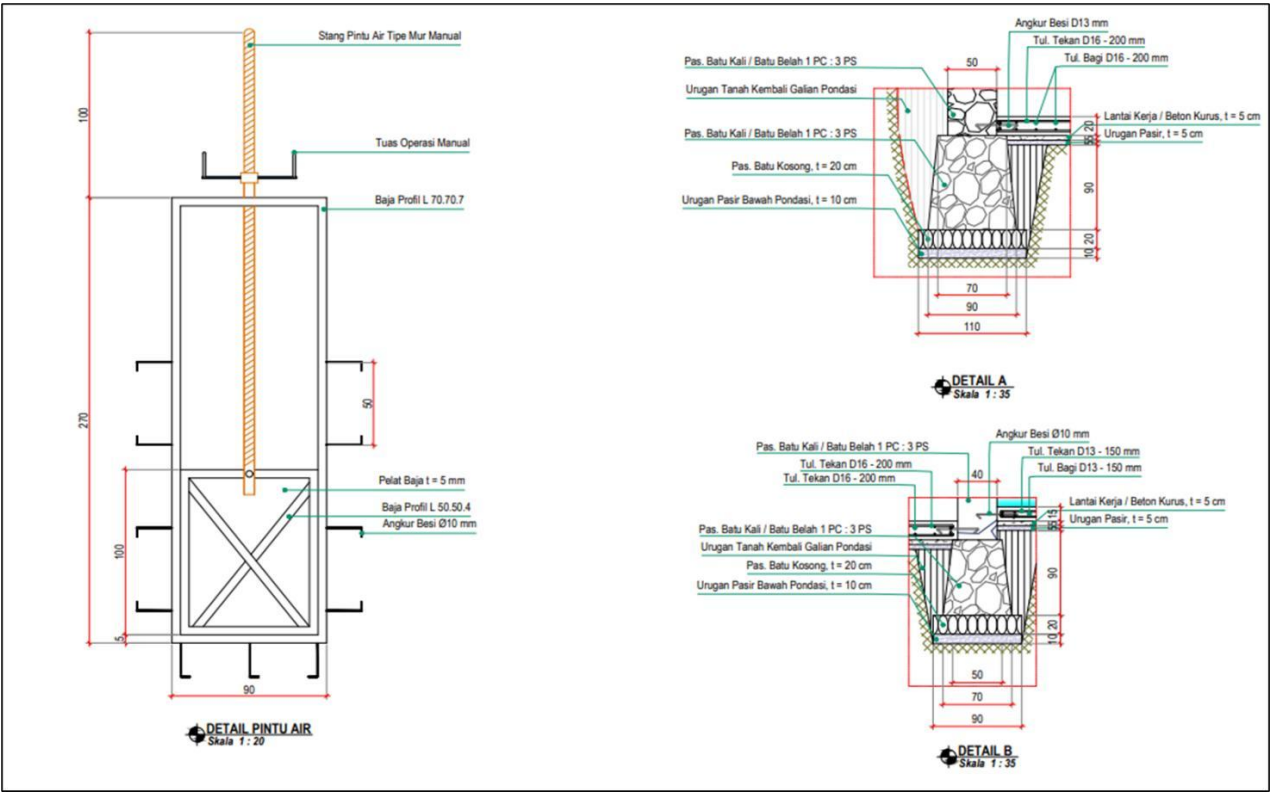

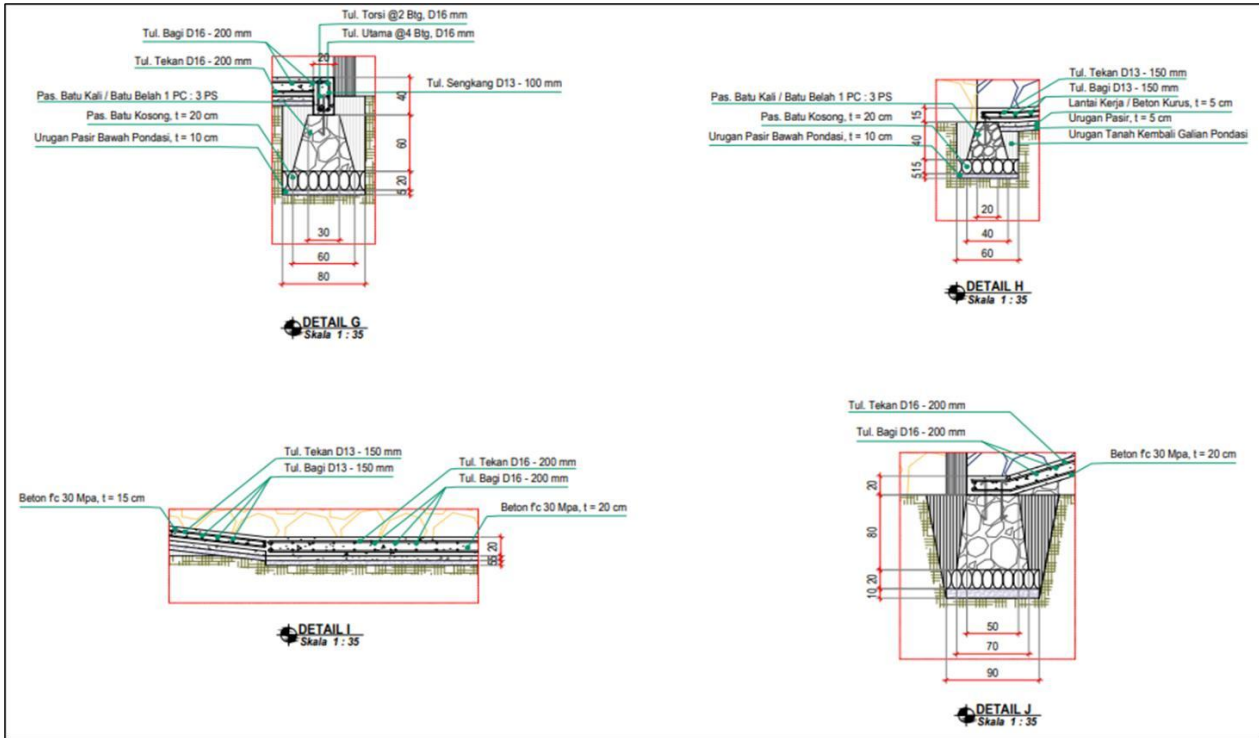

**Detailed drawings of Sloof, Ring beams, Floor Plates and walls of the intake**

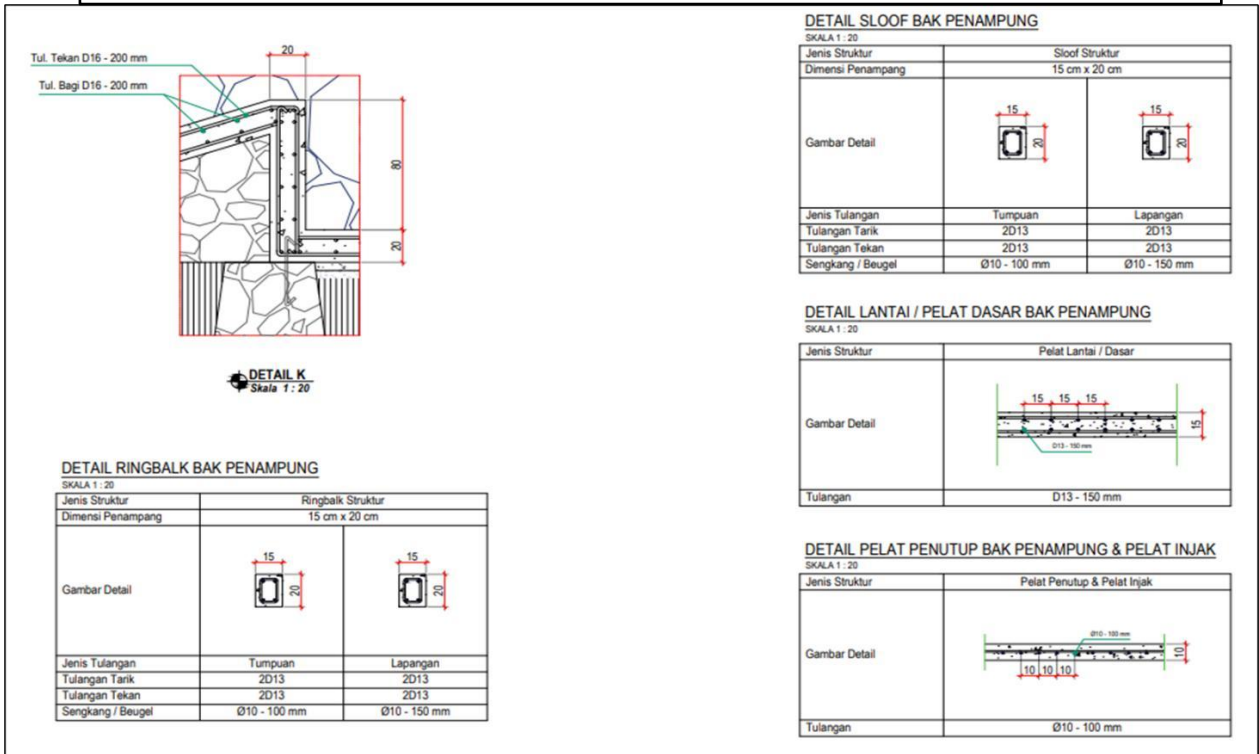

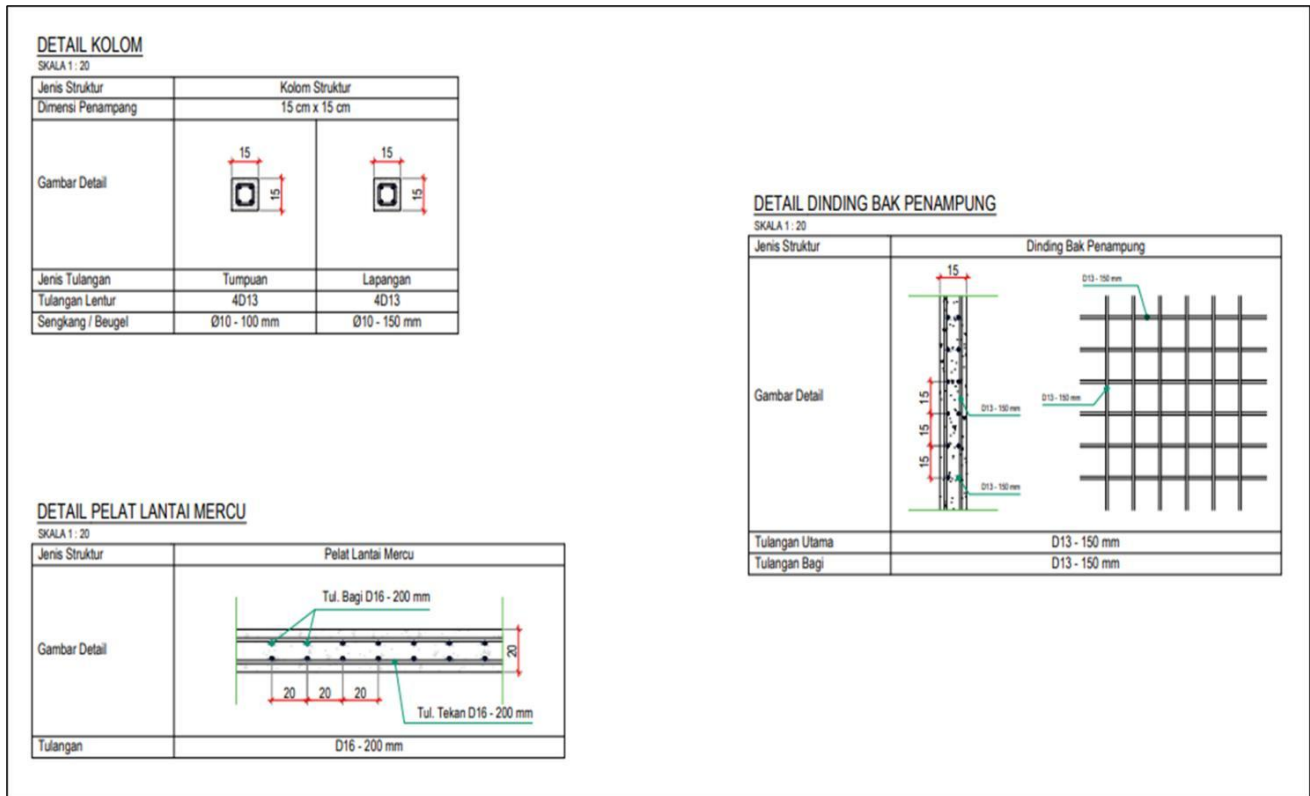

## Conclusion

Based on the results of research and analysis of data on the selection and design of intake at the location of the Wasi River, Jayawijaya Regency, it can be concluded as follows: 1) Through the results of the analysis, it was found that the availability of water in the Wasi River in Jayawijaya Regency was 5.9595 m<sup>3</sup>/s. 2) Based on the analysis, Jayawijaya Regency, especially in Wamena District, found that the water demand is 190.763 liters/second (0.19 m<sup>3</sup>/s). Based on the results, it is necessary to build an intake on the Wasi River in order to help drain water for the needs of the community. 3) The storage basin planned in the Wasi River intake design is 3 x 3 x 3 meters.

## Bibliography

- Anwar, F., & Basyuni, M. (2017). Water distribution systems and urban water management: Case study in Indonesia. *Water Supply*, 17(3), 1034-1045. <https://doi.org/10.2166/ws.2017.0194>
- Chandra, H., & Pratama, A. (2019). Water supply infrastructure development and challenges in rural Papua. *Indonesian Journal of Environmental Studies*, 22(1), 47-55. <https://doi.org/10.2984/ijenviron.22.1.47>
- Direktorat Jenderal Sumber Daya Air. (2013). *Standard perencanaan irigasi: Kriteria perencanaan bagian bangunan utama (headworks) KP-02* (p. 240).
- Fauzi, F., & Anwar, A. (2021). Strategic water conservation in mountainous regions of Indonesia: A case study in Jayawijaya. *Hydrology Science Journal*, 14(2), 102-112. <https://doi.org/10.3390/hydrology.14.02.0102>
- Irawan, F., & Setyawan, M. (2021). Geomorphological and hydrological challenges in water intake design for mountainous areas. *Journal of Civil Engineering*, 26(3), 274-285. <https://doi.org/10.1016/j.jce.2021.02.004>

- Kurniawan, D., & Widodo, A. (2020). A review of water management and system planning in the highlands of Papua. *Jurnal Sumber Daya Air*, 35(3), 197-210. <https://doi.org/10.2108/jsda.35.3.197>
- Li, Y., & Zhang, T. (2019). The impact of climate change on the hydrology of the Wasi River basin. *Climate Change Journal*, 28(1), 75-87. <https://doi.org/10.2139/ssrn.3344431>
- Mulyono, S. (2017). *Perencanaan intake air untuk sistem pengelolaan air minum*. Universitas Gadjah Mada Press.
- Peraturan Pemerintah Republik Indonesia Nomor 82 Tahun 2001. (2001). *Tentang pengelolaan kualitas air dan pengendalian pencemaran air*.
- Peraturan Menteri Pekerjaan Umum Nomor 18/Prt/M/2007. (2007). *Tentang penyelenggaraan pengembangan sistem penyediaan air minum*.
- Kelompok-JRF. *Pedoman perencanaan pengadaan air bersih pedesaan*.
- Pugel, M. P. (n.d.). *Perencanaan sistem penyediaan air bersih di Kecamatan Belitang, Kabupaten Sekadau, Provinsi Kalimantan Barat* (Unpublished manuscript). Fakultas Teknik, Universitas Tanjungpura, Pontianak.
- Silitonga, H. B. (2018). *Perencanaan hidrolis pintu pada bangunan pengambilan air (intake)*.
- Tarmizi, A. (2020). Water supply management in remote areas: Challenges and strategies. *Journal of Sustainable Water Resources*, 12(2), 56-68. <https://doi.org/10.3390/jswr.12.02.0056>